

Green Infrastructure Champions Program

This program is partially funded by the Rutgers New Jersey Agricultural Experiment Station, The Geraldine R. Dodge Foundation, NJ Sea Grant Consortium, The William Penn Foundation and is a collaboration of the Rutgers Cooperative Extension Water Resources Program and the Green Infrastructure Subcommittee of Jersey Water Works.



**Please enter your full name
and affiliation in the chat. This
is how will take attendance.**



IMAGINE A BETTER NEW JERSEY

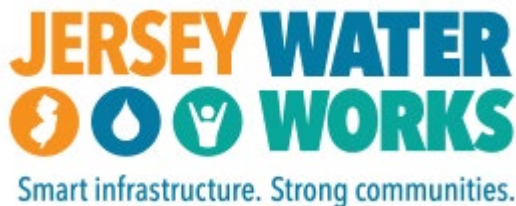

Green Infrastructure Champion Training: Part 3

“Maintaining green infrastructure practices/projects”

February 11, 2022
Virtual Class



RUTGERS
New Jersey Agricultural
Experiment Station



Traditional Stormwater Management Systems

Detention Basins



Traditional Stormwater Management Systems

Retention Basins or Wet Ponds



Catch Basins



Lawn Inlet





Stormwater Detention Basins

How it works:

Basins have outlets that have been designed to detain stormwater runoff for some minimum time to prevent downstream flooding. The basins provide quantity control; they need to be mowed regularly. The concrete low-flow channels should be dry except during and immediately following a storm event (typically 48 hours). Basins can treat stormwater runoff through settling of particles.

Benefits:

- Reduces flooding
- Reduces the need to mow
- Eliminate any use of commercial fertilizers and pesticides



Design Criteria

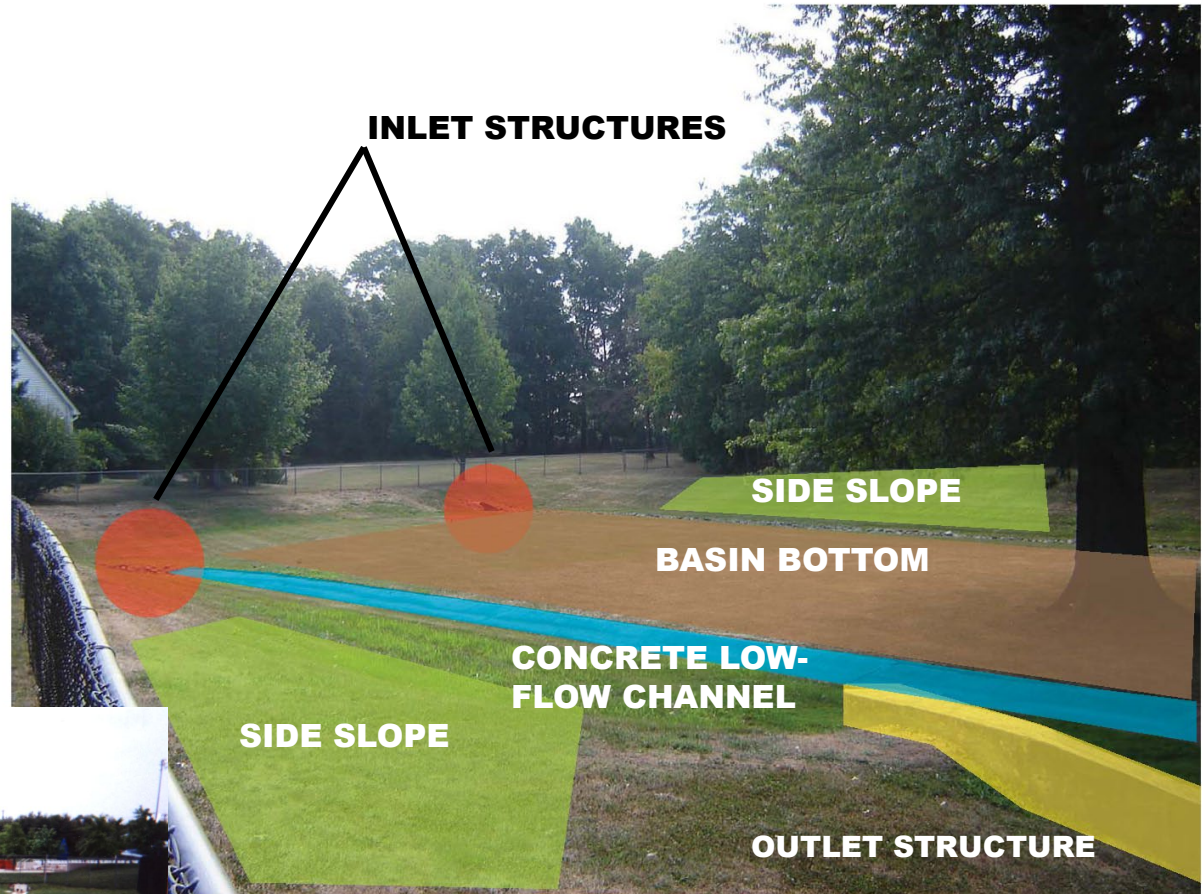

Stormwater Detention Basins

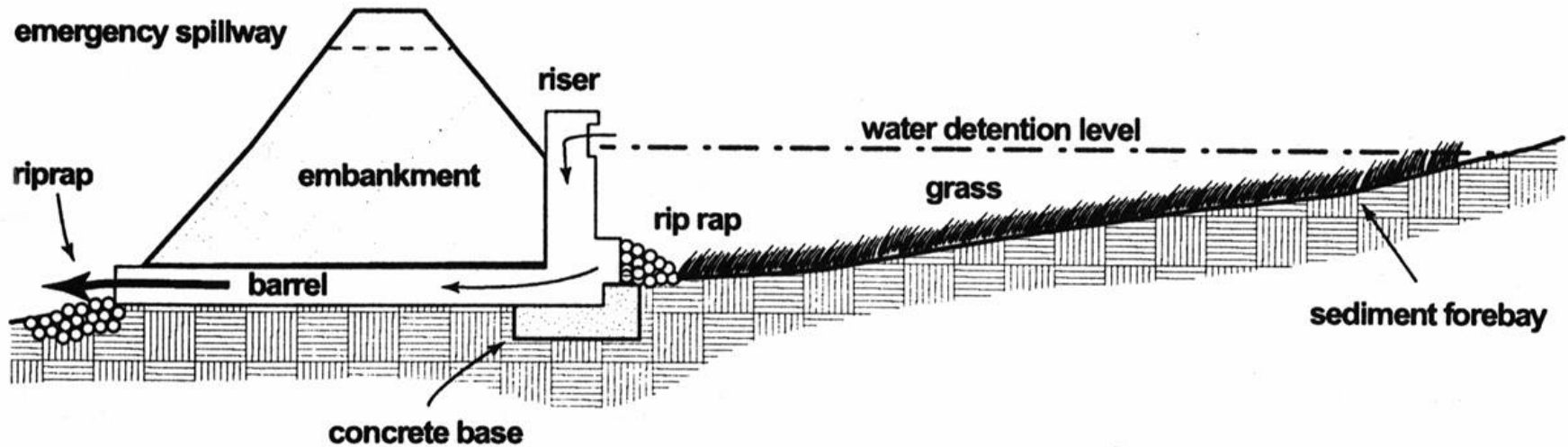

Storage System



Maintained Detention Basins



Common Concerns with Detention Basins

1. Embankment and outlet stabilization
2. Sedimentation
3. Outlet blockages
4. Broken or clogged low-flow channels
5. Standing water or wet soils
6. Floatables and debris
7. Weeds or woody vegetation



1. Embankment and Outlet Stabilization



Embankment
Destabilization



Outlet Destabilization



2. Sedimentation



Accumulation of sediment in basin



3. Outlet Blockage



Outlet blockage by
debris



Outlet blockage by
sediment



4. Broken or Clogged Low-Flow Channels



Broken low-flow
channel



Clogged low-flow
channel



5. Standing Water or Wet Soils



Standing water in detention basin



6. Floatables and Debris



Accumulation of floatables in basin



Basin is a dumping ground



7. Weeds and Woody Vegetation



Woody vegetation in
basin



Invasive species
have overtaken the
basin



Green Infrastructure Champion Training: Part 8

“Retrofitting traditional detention basins with green infrastructure”

April 22, 2022



Green Infrastructure Systems

Vegetative Systems

- Bioretention Systems/Rain Gardens
- Stormwater Planters



Harvesting Systems

- Cistern/Rain Barrel
- Downspout Planter Boxes



Storage Systems

- Street Trees/Stormwater Tree Pits
- Permeable Pavement



Difference between the types of systems:

- Vegetative Systems: focus on reducing water quality impacts. These systems are typically located close to the sources of runoff and can manage the smaller storms of several inches. The main treatment mechanisms are infiltration, filtration, and evapotranspiration.
- Harvesting Systems: focus on the conservation, capture, storage, and reuse of rainwater. These systems are located close to residential and commercial buildings.
- Storage Systems: provide storage of stormwater, quantity control, and infiltrate stormwater runoff. These systems are typically located close to runoff sources within residential, commercial, and industrial landscapes. The main treatment mechanism is reducing peak flows of stormwater by storing it before it enters the sewer system.



Bioretention Systems such as Rain Gardens



Landscaped, shallow depression that captures, filters, and infiltrates stormwater runoff



Bioswales



Stormwater Planters and Curb Extensions (Bumpouts)



Bioretention Systems

How it works:

These systems capture, filter, and infiltrate stormwater runoff using soils and plant material. They are designed to capture the first few inches of rainfall from rooftops, parking areas, and streets.

Benefits:

Remove nonpoint source pollutants from stormwater runoff while recharging groundwater

Restore/“mimic” predevelopment site hydrology

- Infiltration
- Evapotranspiration

Improve water quality

- Sedimentation, filtration, & plant uptake
- Microbial activity

Add aesthetic value

- Plant selection



Design Criteria

- The size of the rain garden is a function of volume of runoff to be treated and recharged
- Typically, a rain garden is sized to handle the two-year design storm (3.3 inches of rain over 24 hours)
- Rain gardens range from 75 to 2,500 square feet

6" DEEP RAIN GARDEN – NO SOIL AMENDMENTS

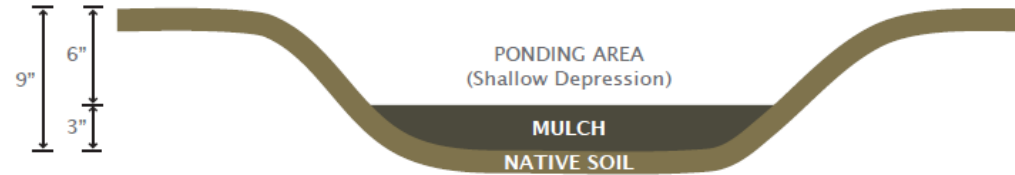

3" DEEP RAIN GARDEN – SOIL AMENDMENTS

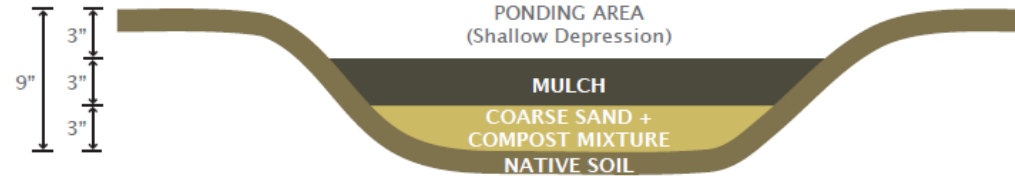

Bioretention Systems / Rain Gardens

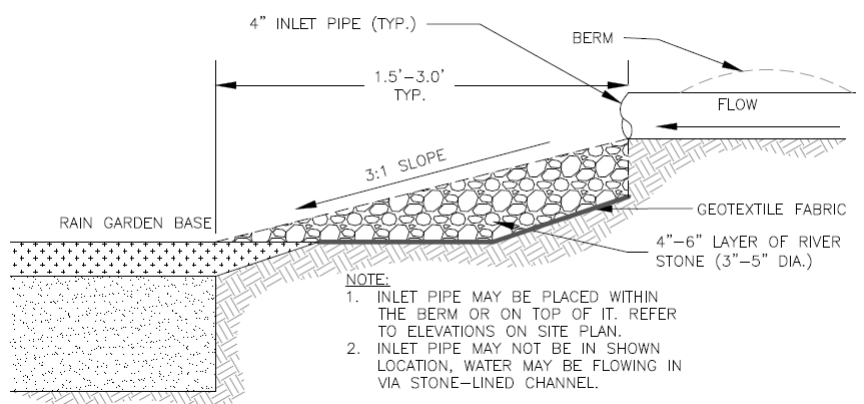
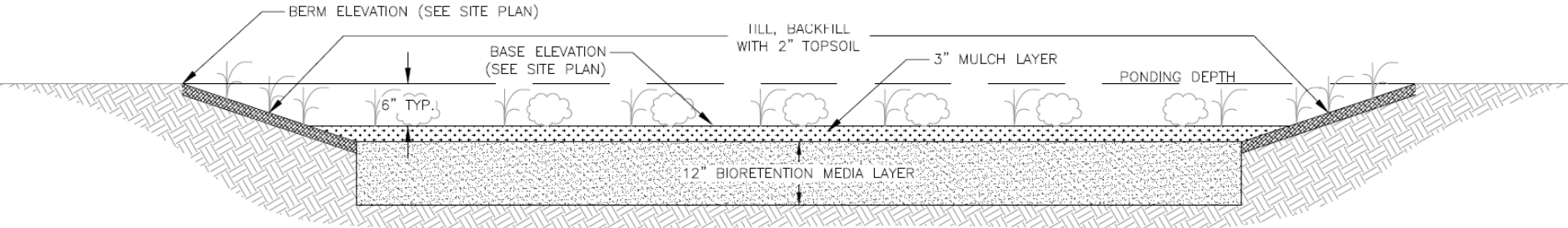

NOTE:

1. INLET PIPE MAY BE PLACED WITHIN THE BERM OR ON TOP OF IT. REFER TO ELEVATIONS ON SITE PLAN.
2. INLET PIPE MAY NOT BE IN SHOWN LOCATION, WATER MAY BE FLOWING IN VIA STONE-LINED CHANNEL.

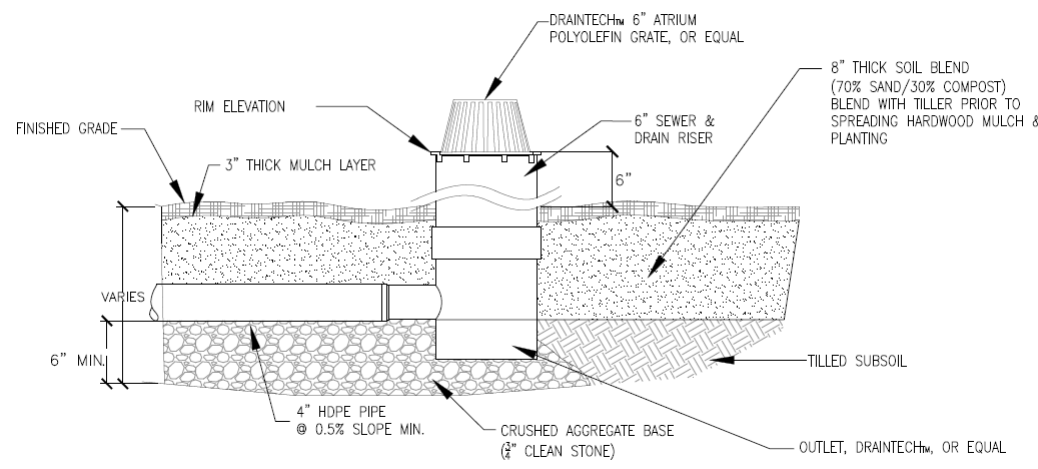



Rain garden installation at Ferry Avenue Library in Camden





Rain garden at Woods Road School in Hillsborough





Rain garden at Hillsborough Municipal Building



Stormwater Planters



Vegetated structures that are built into the sidewalk to intercept stormwater runoff from the roadway or sidewalk



Stormwater Planters

How it works:

- It is a structural bioretention system that is installed in a sidewalk
- Contains a layer of stone that is topped with bioretention media and plants or trees
- Captures stormwater runoff from the roadway and sidewalk
- Once the system fills up, runoff flows back into the street or into an overflow drain which connects to the sewer system

Benefits:

- Allows water to infiltrate into the ground



Stormwater Planters

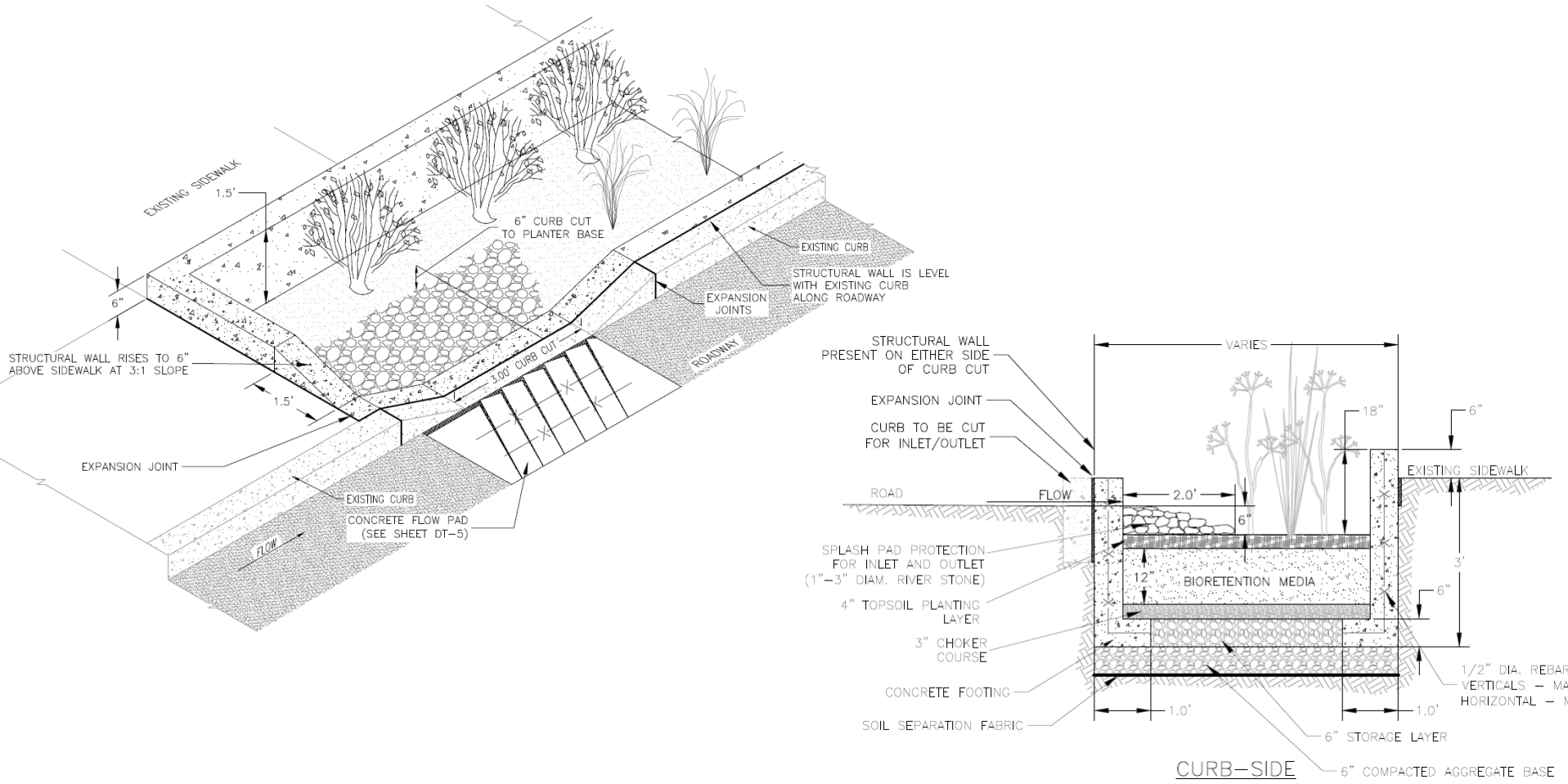



Stormwater Planter at the Brimm School





Stormwater Planters at the Vietnamese Community Garden



Cisterns/ Rain Barrels



These systems capture rainwater, mainly from rooftops, in cisterns or rain barrels. The water can then be used to water a garden, wash vehicles, or for other non-potable uses.



Cistern/ Rain Barrel

How it works:

- Capture, diversion, and storage of rainwater

Benefits:

- Eliminates need for complex and costly distribution systems
- Provides additional water source
- Landscape irrigation
- Reduces flow to stormwater drains
- Reduces non-point source pollution
- Delays expansion of existing water treatment plants
- Reduces consumer utility bills





Cistern at the Neighborhood Center





Cistern at St. Bartholomew's Church





Cistern at Front Street Community Garden



Downspout Planters



Wooden or concrete boxes with plants installed at the base of the downspout that provide an opportunity to beneficially reuse rooftop runoff



Downspout Planter: Harvesting System

How it works:

- Constructed boxes placed against buildings
- Contains stone/gravel topped with sandy compost mixture and plants
- Designed with underdrain and overflows
- Disconnects downspouts

Benefits:

- Aesthetics
- Provides some rainfall storage



Downspout Planter: Harvesting System

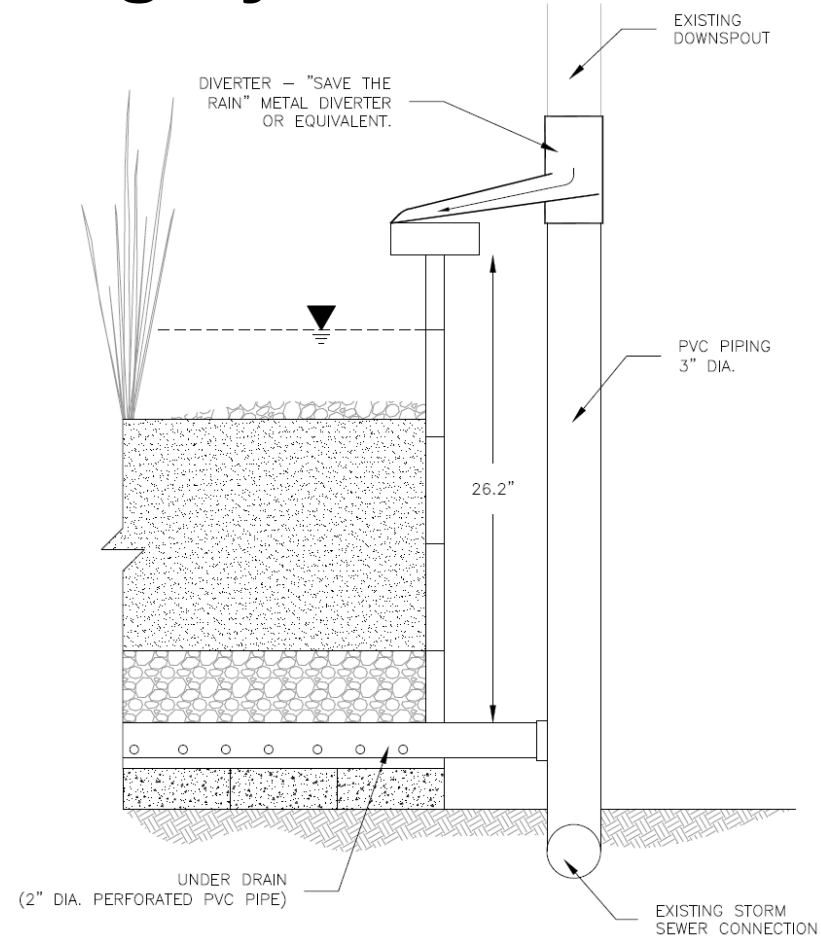
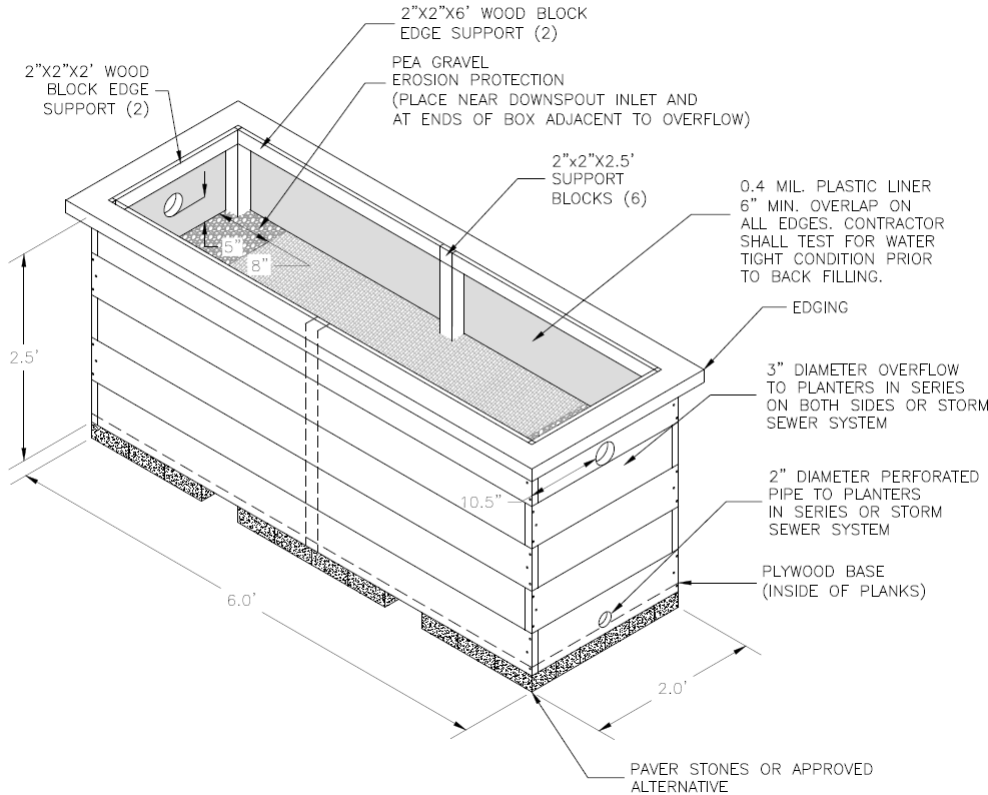



Downspout Planter Boxes at Acelero





Downspout Planter Boxes at Davis School



Stormwater Tree Pits/Street Trees



Pre-manufactured concrete boxes or enhanced tree pits that contain a special soil mix and are planted with a tree or shrub



Stormwater Tree Pits/Street Trees

How it works:

- They filter stormwater runoff from a roadway or parking lot but provide limited storage capacity
- They are typically designed to quickly filter stormwater and then discharge it to the local sewer system

Benefits:

- Improved aesthetics
- Improved air quality
- Creation of wildlife habitat
- Increased groundwater infiltration and recharge
- Reduced heat island effect



Stormwater Tree Pits/Street Trees

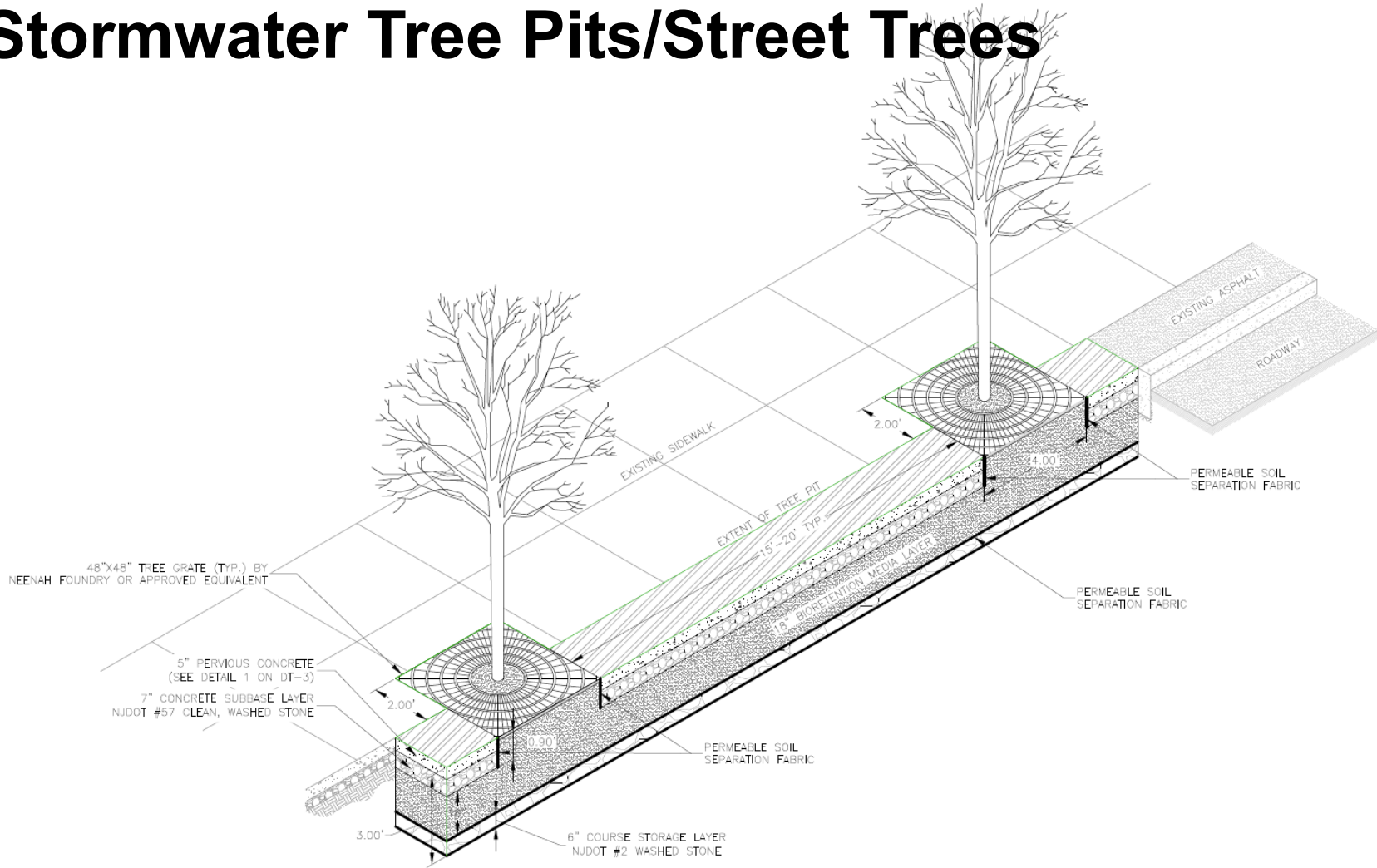

Permeable Pavement



These surfaces include pervious concrete, porous asphalt, permeable pavers, and grid pavers. These materials allow water to quickly pass through the material into an underlying layered system of stone that holds the water, allowing it to infiltrate into the underlying uncompacted soil.



Permeable Pavement

How it works:

- Underlying stone reservoir
- Porous asphalt and pervious concrete are manufactured without "fine" materials to allow infiltration
- Grass pavers are concrete interlocking blocks with open areas
- Ideal application for porous pavement is to treat a low traffic or overflow parking area

Benefits:

- Manage stormwater runoff, minimize site disturbance, promote groundwater recharge
- Low life cycle costs, alternative to costly traditional stormwater management methods
- Contaminant removal as water moves through layers of system
- Allows runoff to flow through the surface to an underlying storage layer

POROUS ASPHALT

It is common to design porous asphalt in the parking stalls of a parking lot. This saves money and reduces wear.

DRAINAGE AREA

The drainage area of the porous asphalt system is the conventional asphalt cartway and the porous asphalt in the parking spaces. Runoff from the conventional asphalt flows into the porous asphalt parking spaces.

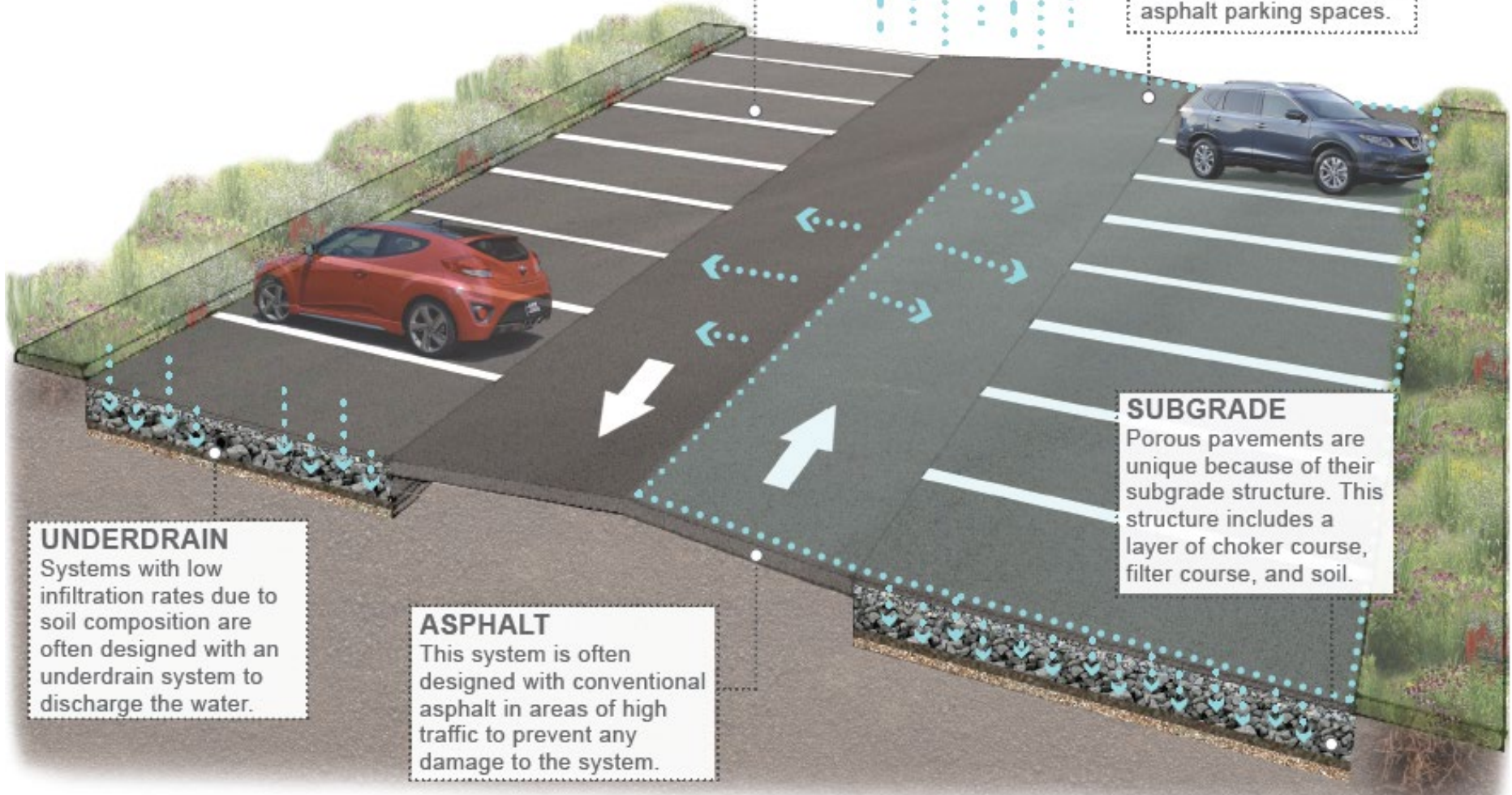

UNDERDRAIN

Systems with low infiltration rates due to soil composition are often designed with an underdrain system to discharge the water.

ASPHALT

This system is often designed with conventional asphalt in areas of high traffic to prevent any damage to the system.

SUBGRADE

Porous pavements are unique because of their subgrade structure. This structure includes a layer of choker course, filter course, and soil.

Permeable Pavement

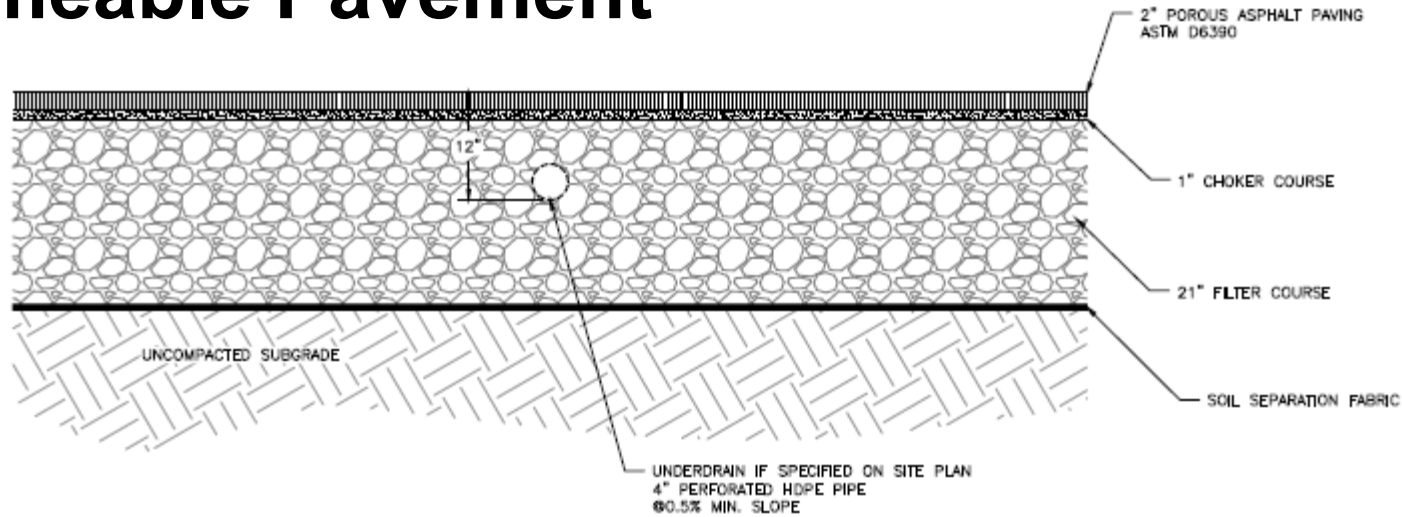



Porous Pavement at Yorkship School (Asphalt)





Porous Pavement at Wiggins School (Concrete)



MAINTENANCE PROCEDURES



Rain Garden/Bioretention System Maintenance

- Remove litter, weeds, water, mulch, and trim
- Inspect for sediment buildup, the health of the vegetation, and erosion
- Clean out and inspect outlets, inlets, overflow risers, etc.
- Keep inlets free and clear so water does not bypass the system



Landscape Maintenance

- Trees
 - watering
 - pruning
- Vegetation
 - weeding
 - mulching
 - watering
 - pruning/cutback
 - landscape replacement



Landscape Maintenance

- General Maintenance
 - Frequency:
 - Annually
 - Tools and supplies:
 - Trash bags, gloves, shovels
 - Soil amendment with organic matter:
 - Years 2 and 4
 - Apply 2 inches of compost into 2 inches of top soil
 - No contact with exposed roots or the trunk of the tree/ shrub
 - Keep weed whackers and lawn mowers more than 2 feet from the trunk



Landscape Maintenance

- Pruning (improves the strength of plants, prevents pest problem, improves safety/security for residents/visitors, reduces future maintenance)
 - Frequency:
 - Year one remove damaged and dead branches
 - Year three correction of structural issues
 - Tools and supplies:
 - Trash bags, gloves, saw, pruners, loppers



Landscape Maintenance

- Maintenance of Vegetation
 - Frequency:
 - Checking vegetation for damage caused by a lawnmower, string trimmers, edger, or other power equipment
 - Weeding: early and often- 3x spring, 1x fall and summer
 - Pull weeds from their roots, use tool if it is difficult
 - Avoid compacting the soil and other plants
 - Remove invasive plants
 - Tools and supplies:
 - Trash bags, gloves, shovels, trowels, weed id guide



Types of Common Invasive Plants:



Asiatic
Bittersweet



Japanese
Stilt Grass



Japanese
Honeysuckle



Types of Common Invasive Plants:



Garlic
Mustard



Mugwort



Multiflora
Rose



Landscape Maintenance

- Mulching
 - Frequency:
 - apply 2-3 inches of mulch in the spring
 - Keep mulch away from the stem of the plants
 - May need to remove or mix up old mulch that is already there
 - Tools and supplies:
 - Trash bags, gloves, shovels, hardwood mulch



Landscape Maintenance

- Watering:
 - Frequency:
 - 1 inch the first week installed
 - ½ inch the first 4-6 weeks of the growing season for years 2 and 3 and for drought in years 2 and 3
 - Water the roots not the leaves
 - Soil should be moist 2 -3 inches below grade
 - Properly used hoses are more efficient than sprinklers
 - Tools and supplies:
 - Hose and water source
 - Gator bags



Landscape Maintenance

- Removal of dead vegetation:
 - Frequency:
 - After winter ends but before new growth appears in the spring
 - Tools and supplies:
 - Trash bags, gloves, gardening scissors, clippers
- Landscape Cutback:
 - Fall cleanup up includes cutting perennials back 4 inches above the ground
 - Some plants like iris shouldn't be cut back while they are still green



Landscape Maintenance

- Landscape Plant Replacement (involves replacing dead, missing, dead or diseased plants)
 - Frequency:
 - Planting should be done in the spring or the fall
 - Tools and supplies:
 - Trash bags, gloves, shovels, replacement plants



Inlet and Outlet Maintenance

1) Inspect:

- Remove catch basin lid/grate with manhole pick and visually inspect for evidence of defects and deterioration
- Record observations

2) Clean structure:

- Use an industrial vacuum or vacuum truck hose to remove any collected materials
- Inspect hardware and replace once inspected
- Record observations

3) Replace lid/grate; and clean up



River Stone Specific Maintenance

- River Stone Maintenance
 - Remove trash or debris from the site
 - Remove weed growth
 - Rake out the rock to make it even and replenish the river stone if it seems shallow or needed
 - Frequency:
 - Annually in the spring
 - Tools and supplies:
 - Rake
 - River stone if there are some missing or not enough
 - Trash bags, gloves

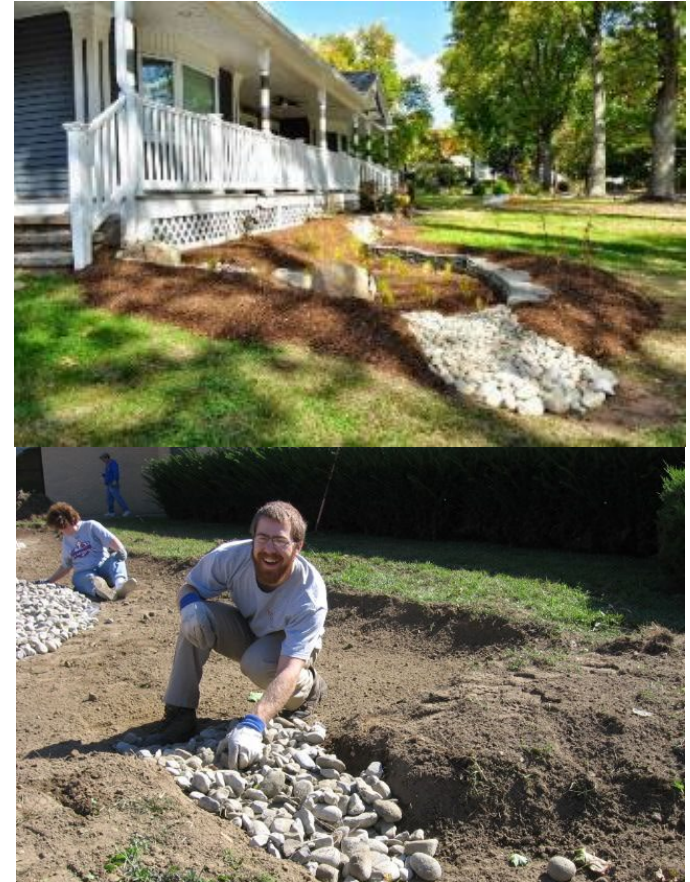

Detention Basin Maintenance

1. Vegetation management

Mowing should be done where/when it is needed (traditionally, 10-14 times per year); effective groundcovers must be kept healthy to prevent erosion and damage to the system.

2. Debris and litter removal

Inlets and outlets should be regularly cleared of debris and litter to prevent obstructions and reduced efficiency of the system.

3. Mechanical components maintenance

All mechanical equipment, such as gates, valves, locks, or other components must be kept in working order should an emergency arise.

4. Inspections

Regular inspections by designated personnel, owner, or operator should be made and clear records kept.



NJ BMP Maintenance Manual Requirements

1. Identify person/s responsible for preventive and corrective maintenance
2. Identify specific preventive and corrective maintenance tasks and detailed information on specific structural components or nonstructural measures
3. Provide a schedule of regular inspections and tasks
4. Provide cost estimates of maintenance tasks
5. Include detailed logs of all preventive and corrective maintenance performed
6. Identify specialized tools or equipment needed
7. Recommend corrective responses if emergency arises
8. Provide guidance for safety during inspections and maintenance
9. Identify approved disposal and recycling sites and procedures for sediment, trash, and debris
10. Include an as-built construction plan





Stormwater Management

- › Green Infrastructure in NJ
- › Stormwater Management Rule
- › Stormwater Management Rule FAQs
- › NJ Stormwater BMP Manual
- › Maintenance Guidance
- › BMP Manual Chapters for Comment
- › MTD Certifications and Guidance
- › Additional Guidance Documents

Stormwater Permitting

- › Municipal Stormwater P-
- › General Stormwater P-

Maintenance Guidance

The guidance on this page is intended to assist design engineers and responsible parties with complying with the maintenance requirements for stormwater management measures. The Maintenance Guidance can be customized to allow for specific considerations in design, site conditions, and responsible party needs.

Note: Documents were drafted using Microsoft Office® 2010, depending on settings, format of the texts and graphics in the files may change

Introduction of NJDEP Stormwater Field Manual

This Video provides an overview of the Stormwater Field Manual, Field Manual Plan, Field Manual Record, and Field Manual Log.

The Stormwater Field Manual includes templates for basic design information, checklists, visual aids, reference documents, and maintenance records. This provides a systematic method to assist maintenance crews in performing field work and retaining records. Each Field Manual was developed with the consideration of essential maintenance requirements for each type of stormwater measure addressed in the corresponding Structural Stormwater Management Measures subchapters within the [NJ Stormwater Best Management Practices Manual](#).

The Stormwater Field Manual includes templates for basic design information, checklists, visual aids, reference documents, and maintenance records. This provides a systematic method to assist maintenance crews in performing field work and retaining records. Each Field Manual was developed with the consideration of essential maintenance requirements for each type of stormwater measure addressed in the corresponding Structural Stormwater Management Measures subchapters within the [NJ Stormwater Best Management Practices Manual](#).

- [Bioretention Systems](#)
- [Dry Wells](#)
- [Grass Swales](#)
- [Infiltration Basins](#)
 - [Surface Infiltration - Extended Detention](#)
 - [Surface Infiltration](#)
- [Manufactured Treatment Devices](#)
- [Pervious Paving Systems](#)
- [Sand Filters](#)
 - [Sand Filter with Infiltration](#)
 - [Sand Filter with Underdrain](#)
- [Standard Constructed Wetlands](#)
- [Subsurface Gravel Wetlands](#)
- [Surface Extended Detention Basins](#)
- [Vegetative Filter Strips](#)
- [Wet Ponds](#)

Maintenance Logs and Inspection Records

- [Maintenance Logs and Inspection Records](#)

https://www.nj.gov/dep/stormwater/maintenance_guidance.htm
See handout.

Overview of Maintenance Guidance

Stormwater Management Measures
Maintenance Plan & Field Manual

Development Name
Address
Block(s) / Lot(s)
Township, County

Party Responsible for Maintenance:

Address: _____
Contact Person(s): _____ Phone: _____
Report by: _____ Date: _____

Single recorded as
Dist. Book # _____ Page # _____ of _____ County Dist. or Dist. _____
Certification: 08/11/2011 - 08/11/2012

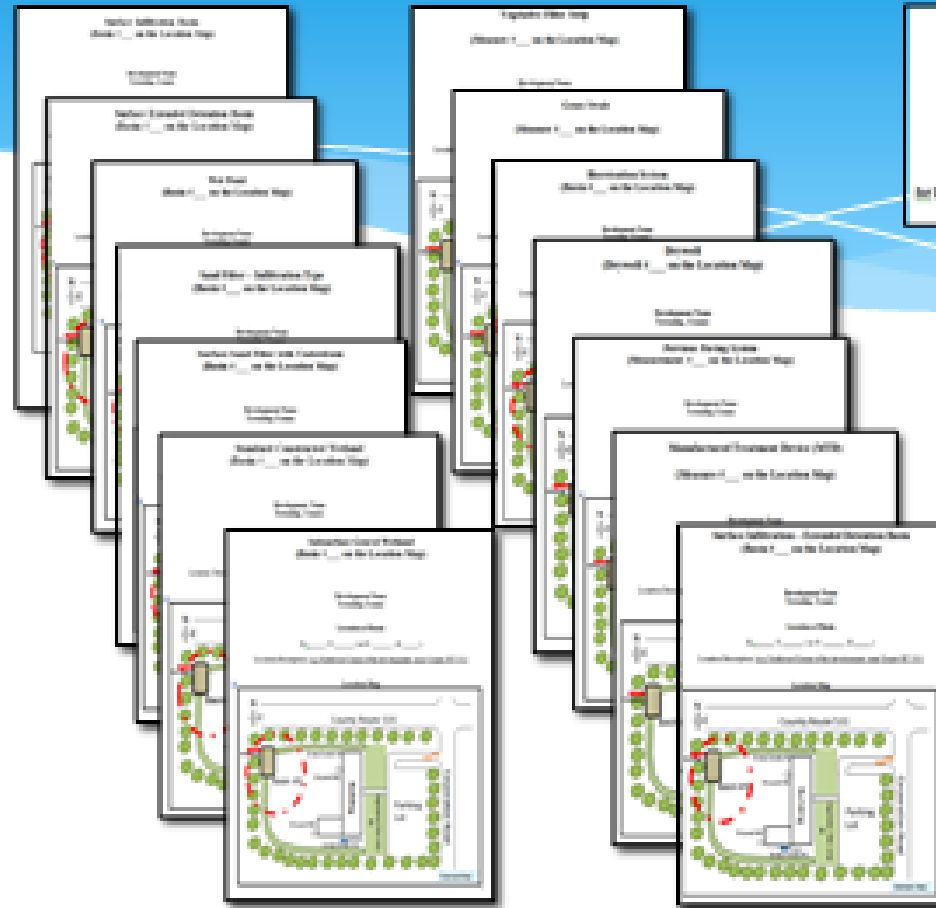

Stormwater Management Measures
Maintenance Plan & Field Manual

Record Log
for Inspection Checklist and Maintenance Work Orders

One Template
of
Maintenance Plan

Fourteen Templates of Field Manuals
for Fourteen Types of
Stormwater Management Measures

One Template
of
Maintenance Log

Additional Best Management Practices Maintenance Procedures



Cistern / Rain Barrel Maintenance

- Release the water before the next rain event
- Rain barrels, cisterns, and downspouts should be inspected and cleaned regularly
- Seals on the infrastructure need to be inspected to prevent mosquito infestation
- Winterize

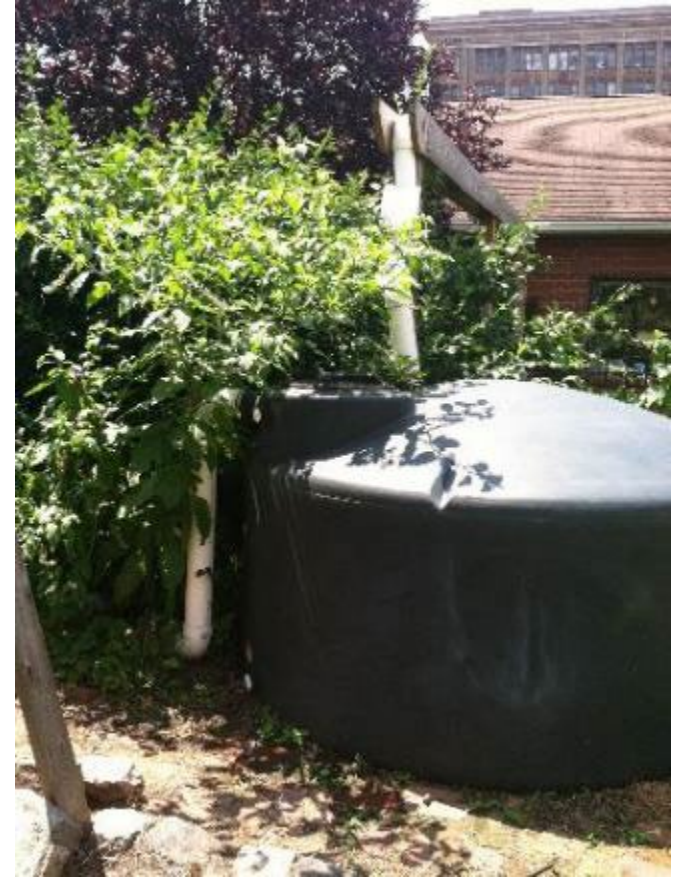

Cistern/ Rain Barrel Maintenance

- Cistern/Rain Barrel (provides supplemental water supply for irrigation and other nonpotable water use)
 - Frequency:
 - Annually release all the water before the winter
 - Tools and supplies:
 - Trash bags, gloves, wrench
 - Procedure:
 - Refer to guidance document in handout



Planter Box Maintenance

- Apply mulch / stone
- Install plantings
- Remove weeds
- Check/maintain inflow
- Keep overflow clear of debris
- Ensure proper drainage
- Winterize



Permeable Pavement Maintenance

- Porous Pavement Vacuuming
- Porous Pavement Power Washing
- Porous Paver Maintenance (Restoring Aggregate)
- Winter Maintenance for Porous Pavement



Permeable Pavement Maintenance

- Permeable Pavement Vacuuming (process removes sediment which can lead to clogging of the porous surface which prevents infiltration of water)
 - Frequency:
 - Semi-annually for porous asphalt, porous concrete, flexible porous pavement
 - Annually for porous pavers
 - Tools and supplies:
 - Porous pavement vacuum
 - Water source
 - Trash bags, gloves, safety cones, street broom



Permeable Pavement Maintenance

- Porous Pavement Power Washing (should be done if pavement is clogged; NEVER power wash porous pavers)
 - Frequency:
 - Once every three years
 - Power wash after thorough vacuuming
 - Perform task in the spring
 - Tools and supplies:
 - Power washer
 - Water source
 - Trash bags, gloves, safety cones, street broom



Permeable Pavement Maintenance

Porous Pavers Maintenance

1) Inspect:

- Look for damage to the surface of the porous pavement (clogs)
- Record observations in maintenance report log

2) Prepare Site:

- Dispose of trash and debris
- Sweep away any loose debris

3) Clean out clogged voids

- Use a manhole pick to clean out the voids till you are able to see clean aggregate



Permeable Pavement Maintenance

Porous Pavers Maintenance (restoring aggregate)

- Frequency:
 - When gravel infill is less than $\frac{1}{2}$ inch of the paver surface
 - Perform after vacuuming
- Tools and supplies:
 - Shovel, manhole pick, wheelbarrow
 - Cleaned washed small aggregate
 - Trash bags, gloves, safety cones, street broom



Permeable Pavement Maintenance

- Winter Maintenance for Permeable Pavements Procedures
 - Frequency:
 - As necessary following snowfall and/or icy conditions
 - Tools and supplies:
 - Truck with snow plow
 - Salt
 - Hand shovel



Permeable Pavement Maintenance

Winter Maintenance for Porous Pavements Procedures

1) Inspect:

- If location is not visible, look at site plan to identify where its located
- Locate where obstacles are located like speed bumps, bushes, trees so the snowplow can be raised
- Record observations in maintenance report log

2) Plow Site:

- Use a rubber plow blade
- Plow 1" above the pavement to prevent hitting the plow on an edge or a paver and ripping it up

3) Storage of snow piles:

- Don't store snow piles on top of porous pavement surfaces; move the snow piles on lawn or non porous pavement

4) Salting

- Use in moderation

5) Record observations in maintenance report log and clean up



TROUBLESHOOTING AND PLANNING



Issues and Concerns: Vehicle Safety

- Branches/debris in roadway or parking area
- Lines of sight at intersections or parking areas
- Water overflow and icing in the roadway



Issues and Concerns: Sediment & Debris

- Trash accumulation
- Sediment accumulation
- Erosion
- Dumping
- Road salt and sand
- Bare soils



Issues and Concerns: Clogging

- Leaves and plant material
- Sediment
- Debris
- Ponding
- Filter screen or fabric
- Stone



Issues and Concerns: Ponding

- Standing water for more than 72 hours
- Saturated soils
- Plant loss
- Poor soil infiltration
- High groundwater
- Insufficient drain piping
- Too much water



Issues and Concerns: Winterizing a Cistern

- Drain all piping, storage drums, and fixtures
- Clean all filters and screens
- Divert flow from storage tanks



Planning for Maintenance: Prescriptive Schedules

- A defined frequency for required maintenance tasks
- Set schedule
- Clear plan
- Straight forward budget
- Refer to the Green Infrastructure Maintenance Log
- **Asbuilt Drawing**



Green Infrastructure Maintenance Log



GREEN INFRASTRUCTURE MAINTENANCE LOG

Project Name: _____

Year: _____

Practice: _____

Month:	Inspection Date:	Initial:	Observation Notes:	Contact RCE:		Last Rain Date:
				Y	N	
January				Y	N	
February				Y	N	
March				Y	N	
April				Y	N	
May				Y	N	
June				Y	N	
July				Y	N	
August				Y	N	
September				Y	N	
October				Y	N	
November				Y	N	
December				Y	N	

By initialing this document, I agree that I have inspected the above referenced green infrastructure practice on the dates listed above and have abided by the maintenance guidelines provided by the Rutgers Cooperative Extension Water Resources Program.

Setting Prescriptive Schedule & Tasks

- Is the system working properly?
- Does the system meet appearance or aesthetic requirements
- Are there any safety issues
- Define routine tasks



Planning for Maintenance: Adaptive Scheduling

- Relies on frequent or regular inspections to identify specific needs
- Flexible but undefined schedule
- Complete work as needed
- Focus on systems in most need
- More experience required



Planning for Maintenance: Staffing

- Requires a knowledgeable leader or crew chief
- Basic understanding of system function
- Knowledge of plant materials
- Ability to assess the system
- Observe, document, report



Planning for Maintenance: Staffing

- Ability to make minor repairs
- Ability to install replacement plantings
- Ability to communicate with the public
- Skills in adapting to a variety of conditions and sites



Planning for Maintenance: Tools & Equipment

- Basic landscape & gardening equipment (rakes, shovels, pitchforks, pruners)
- Wheel barrow
- Weed trimmer, edger
- Mower
- Trash bags and disposal
- Broom



Planning for Maintenance: Tools & Equipment

- Safety vest, tape, cones
- Gloves
- Tool box with basics:
 - Hammers
 - Pliers
 - Drills
 - Screwdrivers
 - Wrenches
 - Tape Measure
 - Cutters



Planning for Maintenance: Materials

- Mulch
- Plantings
- Seed mix
- Topsoil
- Stone
- Filter fabric
- Trash bags
- Erosion control blanket



Planning for Maintenance: Documenting Maintenance Activity

- Maintenance Report Form
- Digital camera
- Pen & paper
- Clip board



Planning for Maintenance: Documenting Maintenance Activity



Rain Garden Inspection Form

Name of Inspector: _____

Site Name: _____ Date of Inspection: _____

Address: _____ County: _____

When was the last time it rained? _____ how much _____ inches

Rain Garden Inspection (please check)

Are there educational signs within the garden?	____ Yes ____ No
Are there weeds (plants that do not belong there) within the garden? If yes, are these weeds invasive?	____ Yes ____ No ____ Yes ____ No (Use USDA Invasive Plants Field and Reference Guide to identify invasive plants)
Are the plants in the garden healthy? For example: is there any leaf discoloration, fungal growth on the leaves, or pests?	____ Yes ____ No Take photographs of the plants.
Are some plants over-shadowing other plants or are certain plants over-taking the other plants within the garden?	____ Yes ____ No If yes, take photographs and provide description of the plant (if the plant name is known, write it down). Please describe:
Is there litter within the garden?	____ Yes ____ No
Is there sediment accumulation within the garden?	____ Yes ____ No If yes, is the sediment accumulation only in one area or throughout the garden? Please describe:
Is there sediment accumulation on the plants within the garden?	____ Yes ____ No If yes, how many plants are covered with sediment? Please describe:



Rain Garden Inspection Form

Is there evidence of gullying or erosion within the garden?	____ Yes ____ No If yes, where is the gullying mostly occurring? Describe & take photos.
Is there evidence that the mulch has washed away within the garden?	____ Yes ____ No If yes, take photographs of exposed areas.
Are gutters or pipes entering and exiting the garden clear of debris?	____ Yes ____ No ____ N/A If no, take photographs of clogged gutters or pipes.
Is runoff free to enter the garden without any obstructions?	____ Yes ____ No ____ N/A If no, take photographs of areas of blocked flow within the garden.
Take measurements: drainage area and rain garden footprint	<ul style="list-style-type: none"> • Drainage area _____ ft² • Type of drainage area: _____ (rooftop, parking lot, driveway, sidewalk, grassed area, etc.) • Footprint _____ ft²
Is there empty space in the garden?	____ Yes ____ No If yes, estimate how many plants would be needed to fill the gaps.
Say cheese!	Take photographs of the rain garden from all angles

Additional Notes:



QUESTIONS?