

FLANDERS DRIVE DEVELOPMENT

GREEN INFRASTRUCTURE IMPLEMENTATION PROJECT

FLANDERS DRIVE, HILLSBOROUGH TOWNSHIP SOMERSET COUNTY, NEW JERSEY

BLOCK: 182;182.02;182.03 LOT: 12,51-70;1-14;12-15

PROJECT DESCRIPTION:

STORMWATER RUNOFF WILL BE CAPTURED AND TREATED BY VARIOUS GREEN INFRASTRUCTURE SYSTEMS THROUGHOUT THE DEVELOPMENT. RUNOFF FROM THE BUILDING'S ROOFS (69,839 S.F.) WILL BE DIRECTED INTO 37 RAIN GARDENS (750 S.F. EACH) WHERE IT WILL BE CAPTURED, FILTERED AND INFILTRATED. DRIVEWAYS WILL BE CONVERTED INTO PERVIOUS PAVEMENT (156,064 S.F.), TO CAPTURE AND INFILTRATE RUNOFF FROM THE DRIVEWAYS. EIGHTEEN ROAD SIDE RAIN GARDENS (175 S.F. BASE AREA EACH) WITH UNDERGROUND STORAGE IN THE 10' RIGHT-OF-WAY WILL BE INSTALLED TO CAPTURE AND TREAT STORMWATER RUNOFF FROM THE ROADWAYS. A LARGE SCALE BIoretention BASIN (52,000 S.F.) WILL BE INSTALLED IN THE UNDEVELOPED AREAS OF THE NORTHERN SIDE OF DEVELOPMENT TO CAPTURE, STORE, AND TREAT THE STORMWATER RUNOFF.

LIST OF DRAWINGS:

SHEET NAME	TITLE
COVER	COVER SHEET
P-1	EXISTING CONDITIONS PLAN
P-2	CONCEPTUAL SITE PLAN
P-3	CONCEPTUAL BASIN DESIGN PLAN
DT-1	BIoretention BASIN DETAILS
DT-2	STORMWATER PLANTER WITH STORAGE DETAILS
DT-3	STORMWATER PLANTER WITH STORAGE DETAILS CONT.
DT-4	RAIN GARDEN AND PLANTING DETAILS
DT-5	PERVIOUS PAVEMENT DETAILS

LOCATION MAP (N.T.S):

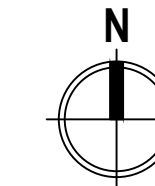
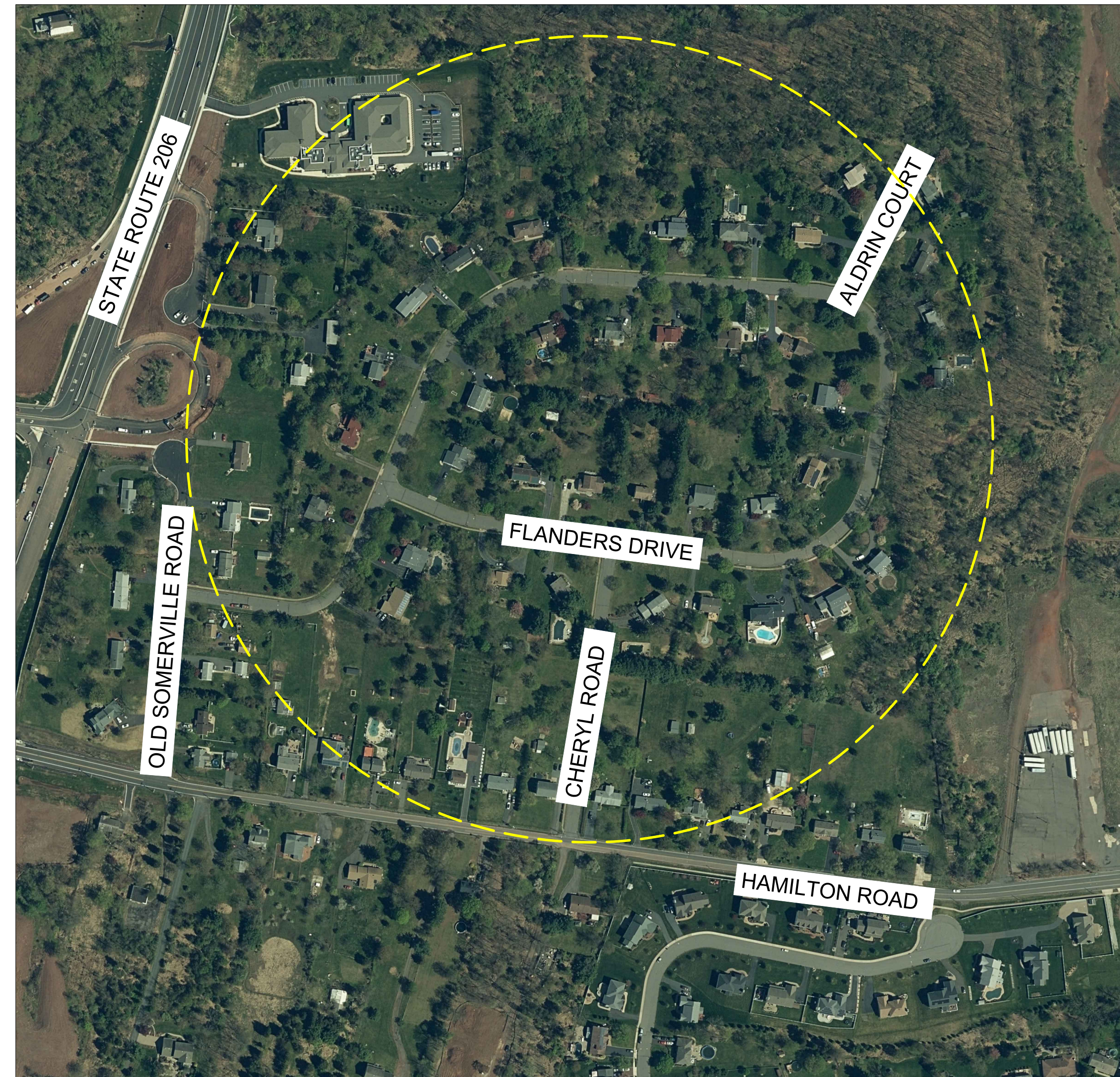

LEGEND:

	EXISTING DRAINAGE AREA
	EDGE OF PAVEMENT
	EXISTING CENTERLINE
	EXISTING FENCE
	EXISTING TREELINE
	EXISTING TREE/SHRUB
	EXISTING BUILDING
	EXISTING UTILITY POLE
	EXISTING WATER LINE
	EXISTING LIGHT POLE
	EXISTING CATCH BASIN
	EXISTING CONTOURS
	LIMIT OF WORK
	PROPERTY LINES
	PROPOSED CONTOURS
	PROPOSED GREEN INFRASTRUCTURE
	FEMA FLOODWAY BOUNDARY
	FEMA 100-YR FLOODPLAIN BOUNDARY
	FEMA 500-YR FLOODPLAIN BOUNDARY
	ROYCE BROOK STREAM

GENERAL NOTES:

- ELEVATION DATA OBTAINED FROM NOAA DIGITAL COASTAL LIDAR. ELEVATION ARE HEIGHT ABOVE MEAN SEA LEVEL SET BY NAVD 1988.
- EXISTING SOILS ARE PENN SILT LOAM, PENN CHANNERY SILT LOAM, REAVILLE SILT LOAM, AND ROWLAND SILT LOAM WHICH ARE CLASSIFIED AS HYDROLOGIC SOIL GROUP C WHICH HAVE LOW INFILTRATION RATES BASED ON THE NRCS WEB SOIL SURVEY (websoilsurvey.sc.egov.usda.gov). THE NRCS WEB SOIL SURVEY ALSO SUGGESTS A DEPTH TO RESTRICTIVE SOIL LAYER <36".
- ANY OVERHEAD AND UNDERGROUND UTILITIES SHOWN ARE FROM FIELD OBSERVATIONS AND ARE NOT A COMPLETE REPRESENTATION. A UTILITY MARKOUT NEEDS TO BE CONDUCTED PRIOR TO MOBILIZATION BY THOSE RESPONSIBLE FOR EXCAVATION. NJ ONE CALL: 811 OR 800-272-1000

PLAN REVISIONS		
REV. DATE	REV. SUMMARY	REV. SHEETS

CHRISTOPHER C. OBROPTA, Ph.D., P.E.
PROFESSIONAL ENGINEER - NJ LICENSE # 37532

DATE: XX/XX/XX
APPROVED: [Signature]
CHECKED: [Signature]
DRAWN: [Signature]

PLAN REVISIONS

No.	DATE	DESCRIPTION
DRAFT		

FLANDERS DRIVE DEVELOPMENT
GREEN INFRASTRUCTURE IMPLEMENTATION PROJECT
FLANDERS DRIVE, HILLSBOROUGH TOWNSHIP
SOMERSET COUNTY, NJ

COVER SHEET

RUTGERS
New Jersey Agricultural
Experiment Station

14 COLLEGE FARM ROAD, NEW BRUNSWICK, NJ

SHEET NAME
COVER

- PLAN NOTES:**
1. CONTRACTOR SHALL SCHEDULE MEETING WITH ENGINEER AND PROPERTY OWNER PRIOR TO MOBILIZATION.
 2. CONTRACTOR SHALL VERIFY ALL INFORMATION INCLUDING ELEVATIONS AND UTILITIES PRIOR TO MOBILIZATION.
 3. CONTRACTOR SHALL BE RESPONSIBLE FOR OBTAINING REQUIRED APPROVALS FROM AUTHORITIES WITH JURISDICTION OVER PROPOSED WORK.
 4. CONTRACTOR SHALL COORDINATE AND CONFIRM PROJECT SCHEDULE AND WORKING HOURS WITH ENGINEER AND PROPERTY OWNER AND PROCEED IN ACCORDANCE WITH LOCAL REQUIREMENTS.
 5. CONTRACTOR SHALL COORDINATE UTILITY MARK OUT PRIOR TO MOBILIZATION. NJ ONE CALL: 811 OR 800-272-1000
 6. CONTRACTOR SHALL HAUL REMOVED DEBRIS OFF SITE UNLESS OTHERWISE NOTED BY PROPERTY OWNER.
 7. CONTRACTOR SHALL CONDUCT PERMEABILITY TESTING TO VERIFY ADEQUATE INFILTRATION RATES IF NOT PREVIOUSLY PERFORMED.

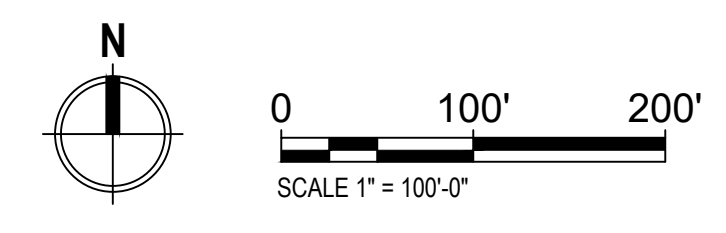

EXISTING PLAN

CHRISTOPHER C. OBROPTA, Ph.D., P.E.
PROFESSIONAL ENGINEER - NJ LICENSE # 37632

DATE: XX/XX/XX
APPROVED: CC
CHECKED: JAL
DRAWN: JAV

DRAFT

FLANDERS DRIVE DEVELOPMENT
GREEN INFRASTRUCTURE IMPLEMENTATION PROJECT
FLANDERS DRIVE, HILLSBOROUGH TOWNSHIP
SOMERSET COUNTY, NJ



EXISTING CONDITIONS AND DEMOLITION PLAN

RUTGERS
New Jersey Agricultural
Experiment Station

14 COLLEGE FARM ROAD, NEW BRUNSWICK, NJ

SHEET NAME
P-1

- PLAN NOTES:**
1. CONTRACTOR SHALL SCHEDULE MEETING WITH ENGINEER AND PROPERTY OWNER PRIOR TO MOBILIZATION AND CONSTRUCTION.
 2. CONTRACTOR SHALL VERIFY ALL INFORMATION INCLUDING ELEVATIONS AND UTILITIES PRIOR TO CONSTRUCTION.
 3. CONTRACTOR SHALL VERIFY ALL PROPOSED MATERIALS WITH PROPERTY OWNER AND ENGINEER PRIOR TO CONSTRUCTION.
 4. CONTRACTOR SHALL STAKE OUT LOCATIONS OF PROPOSED BMPs AND OBTAIN APPROVAL FROM ENGINEER PRIOR TO INSTALLATION.
 5. CONTRACTOR SHALL GRADE SITE AS SHOWN ON PLAN. CUT SOIL SHALL BE REUSED ON SITE FOR FILL LOCATIONS.
 6. CONTRACTOR SHALL HAUL EXCESS SOIL OFF SITE UNLESS OTHERWISE NOTED BY PROPERTY OWNER.
 7. ALL FINISHED ELEVATIONS SHALL MATCH ADJOINING PAVEMENT ENSURING SMOOTH TRANSITIONS AND NO TRIPPING HAZARDS
 8. CONTRACTOR SHALL BE RESPONSIBLE FOR RESTORING ALL AREAS DISTURBED DURING CONSTRUCTION TO ORIGINAL CONDITIONS.

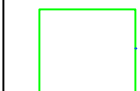
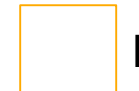
SITE PLAN LEGEND			
	ROADSIDE RAIN GARDEN WITH UNERGROUND STORAGE		BASIN
	ROOF RAIN GARDEN		PERVIOUS PAVEMENT

BIORETENTION BASIN
 TOTAL AREA = 52,000 SF
 BASE AREA = 33,242 SF
 TOB ELEV. = 70'
 BASE ELEV. = 65'

ROOF RAIN GARDENS
 BIORETENTION AREA = 750 SF EACH
 37 TOTAL UNITS (27,750 SF)

PREVIOUS PAVEMENT DRIVEWAYS
 TOTAL AREA = 156,064 SF

ROADSIDE STORMWATER PLANTER WITH STORMTECH STORAGE
 SYSTEM AREA = 575 SF (EACH)
 BIORETENTION AREA = 175 SF (EACH)
 18 ROADSIDE UNITS (10,350 SF)

UNDERDRAIN OUTFLOW

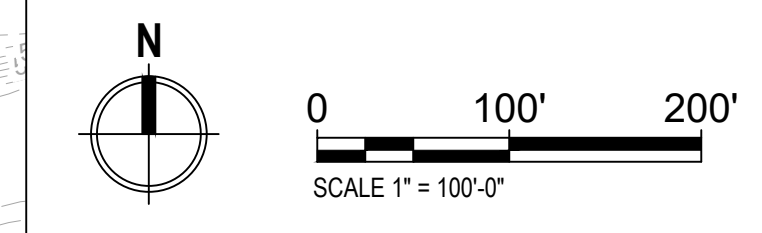
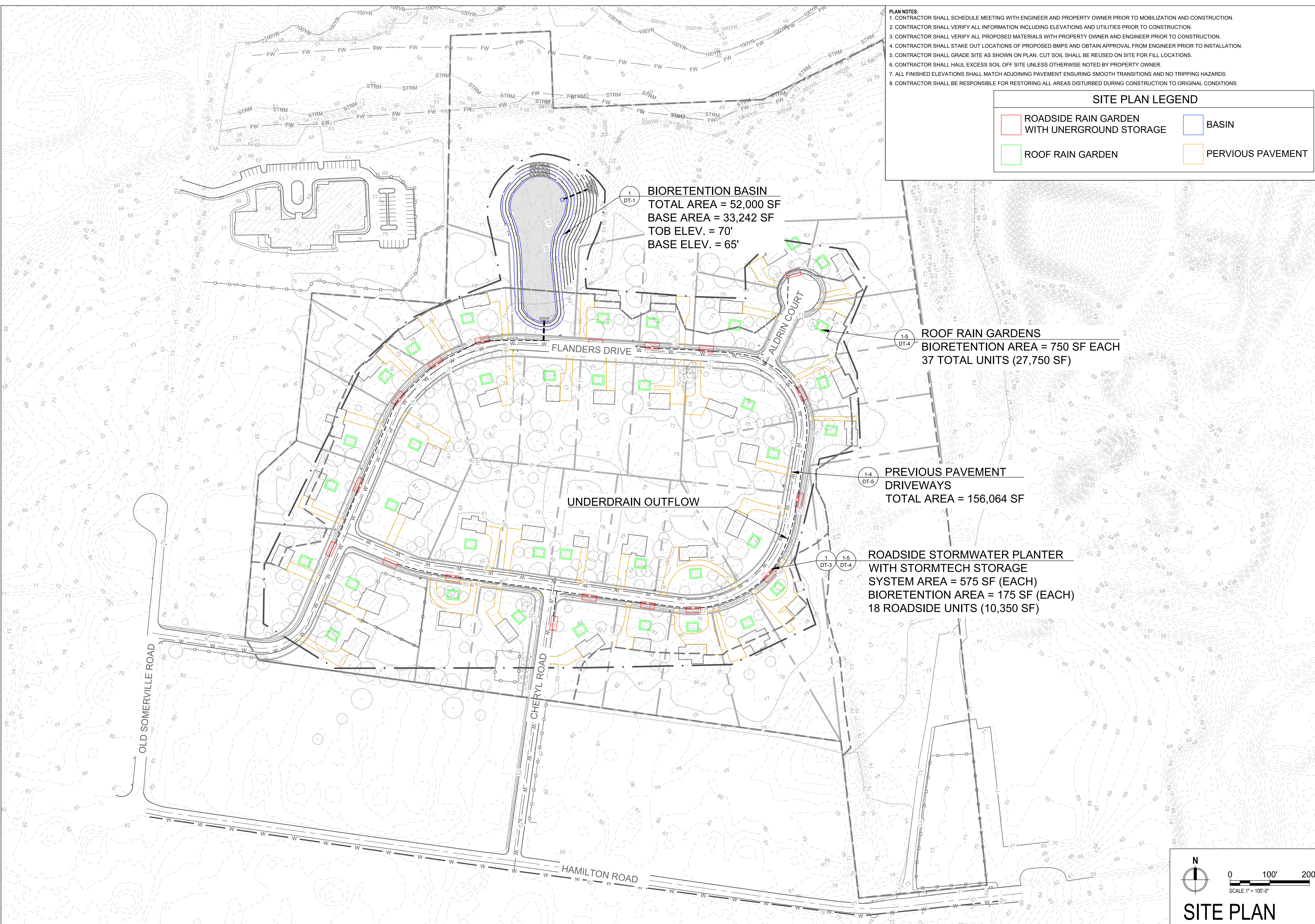

SITE PLAN

CHRISTOPHER C. OBROPTA, Ph.D., P.E.
 PROFESSIONAL ENGINEER - NJ LICENSE # 37532

CHECKED: []
 DATE: XX/XX/XX

APPROVED: []
 DATE: 06/20/24

PLAN REVISIONS

No.	DATE	DESCRIPTION

DRAFT

FLANDERS DRIVE DEVELOPMENT GREEN INFRASTRUCTURE IMPLEMENTATION PROJECT
 FLANDERS DRIVE, HILLSBOROUGH TOWNSHIP
 SOMERSET COUNTY, NJ





CONCEPTUAL SITE PLAN

RUTGERS
 New Jersey Agricultural Experiment Station

14 COLLEGE FARM ROAD, NEW BRUNSWICK, NJ

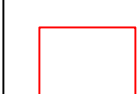
SHEET NAME
 P-2

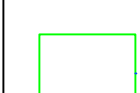
- PLAN NOTES:**
1. CONTRACTOR SHALL SCHEDULE MEETING WITH ENGINEER AND PROPERTY OWNER PRIOR TO MOBILIZATION AND CONSTRUCTION.
 2. CONTRACTOR SHALL VERIFY ALL INFORMATION INCLUDING ELEVATIONS AND UTILITIES PRIOR TO CONSTRUCTION.
 3. CONTRACTOR SHALL VERIFY ALL PROPOSED MATERIALS WITH PROPERTY OWNER AND ENGINEER PRIOR TO CONSTRUCTION.
 4. CONTRACTOR SHALL STAKE OUT LOCATIONS OF PROPOSED BMPs AND OBTAIN APPROVAL FROM ENGINEER PRIOR TO INSTALLATION.
 5. CONTRACTOR SHALL GRADE SITE AS SHOWN ON PLAN. CUT SOIL SHALL BE REUSED ON SITE FOR FILL LOCATIONS.
 6. CONTRACTOR SHALL HAUL EXCESS SOIL OFF SITE UNLESS OTHERWISE NOTED BY PROPERTY OWNER.
 7. ALL FINISHED ELEVATIONS SHALL MATCH ADJOINING PAVEMENT ENSURING SMOOTH TRANSITIONS AND NO TRIPPING HAZARDS
 8. CONTRACTOR SHALL BE RESPONSIBLE FOR RESTORING ALL AREAS DISTURBED DURING CONSTRUCTION TO ORIGINAL CONDITIONS.

SITE PLAN LEGEND			
	ROADSIDE RAIN GARDEN WITH UNGROUND STORAGE		BASIN
	ROOF RAIN GARDEN		PERVIOUS PAVEMENT

CHRISTOPHER C. OBROPTA, Ph.D., P.E.
 PROFESSIONAL ENGINEER - NJ LICENSE # 37532

DATE: 08/20/24
 APPROVED: [Signature]
 CHECKED: [Signature]
 DRAWN: [Signature]

DRAFT

FLANDERS DRIVE DEVELOPMENT
 GREEN INFRASTRUCTURE IMPLEMENTATION PROJECT
 FLANDERS DRIVE, HILLSBOROUGH TOWNSHIP
 SOMERSET COUNTY, NJ

RUTGERS
 New Jersey Agricultural
 Experiment Station

14 COLLEGE FARM ROAD, NEW BRUNSWICK, NJ

SHEET NAME
 P-3

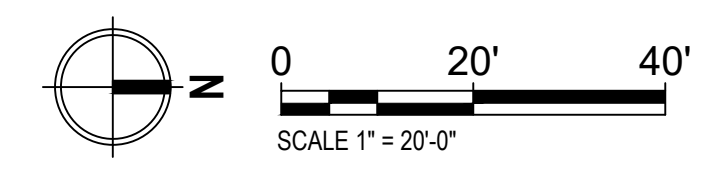
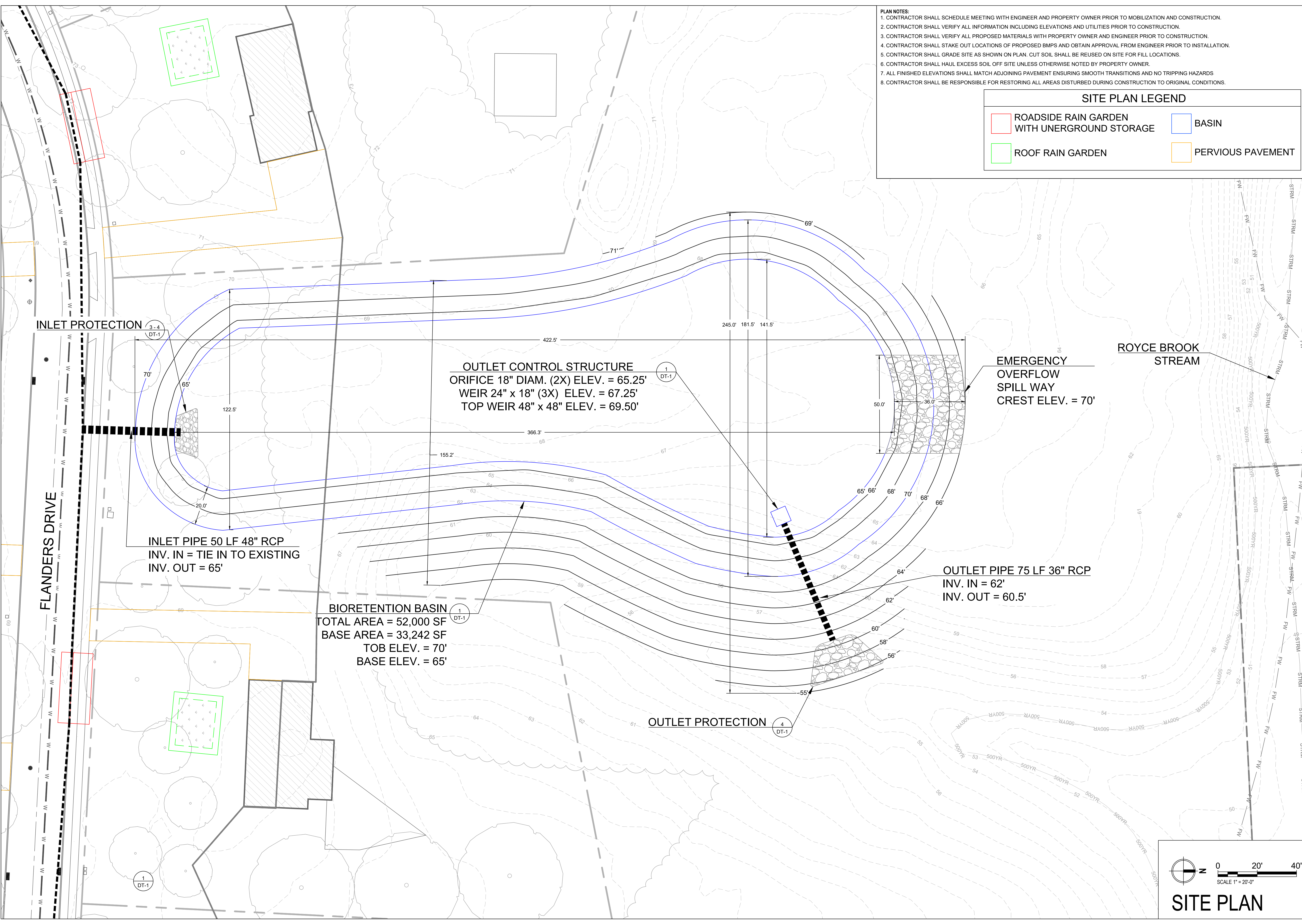

SITE PLAN

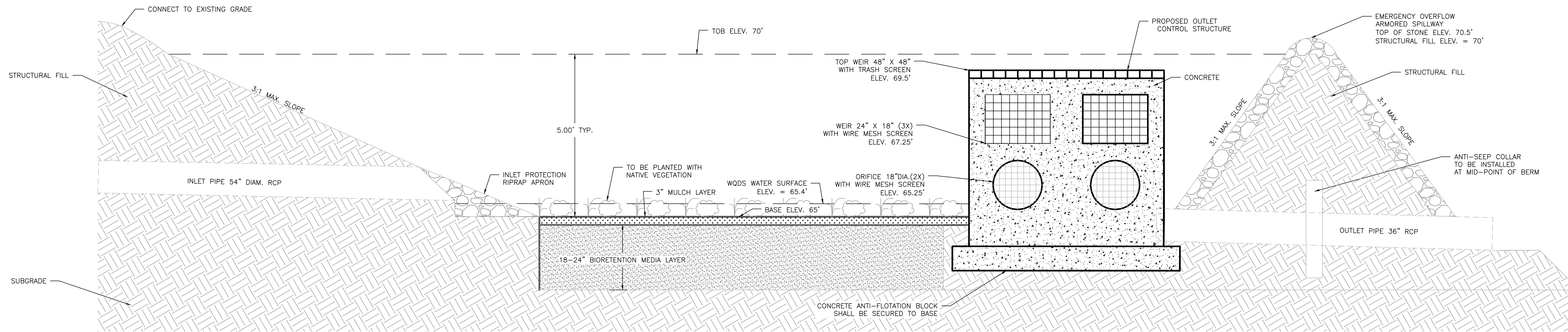

1 BIORETENTION BASIN DETAIL
DT-1 N.T.S.

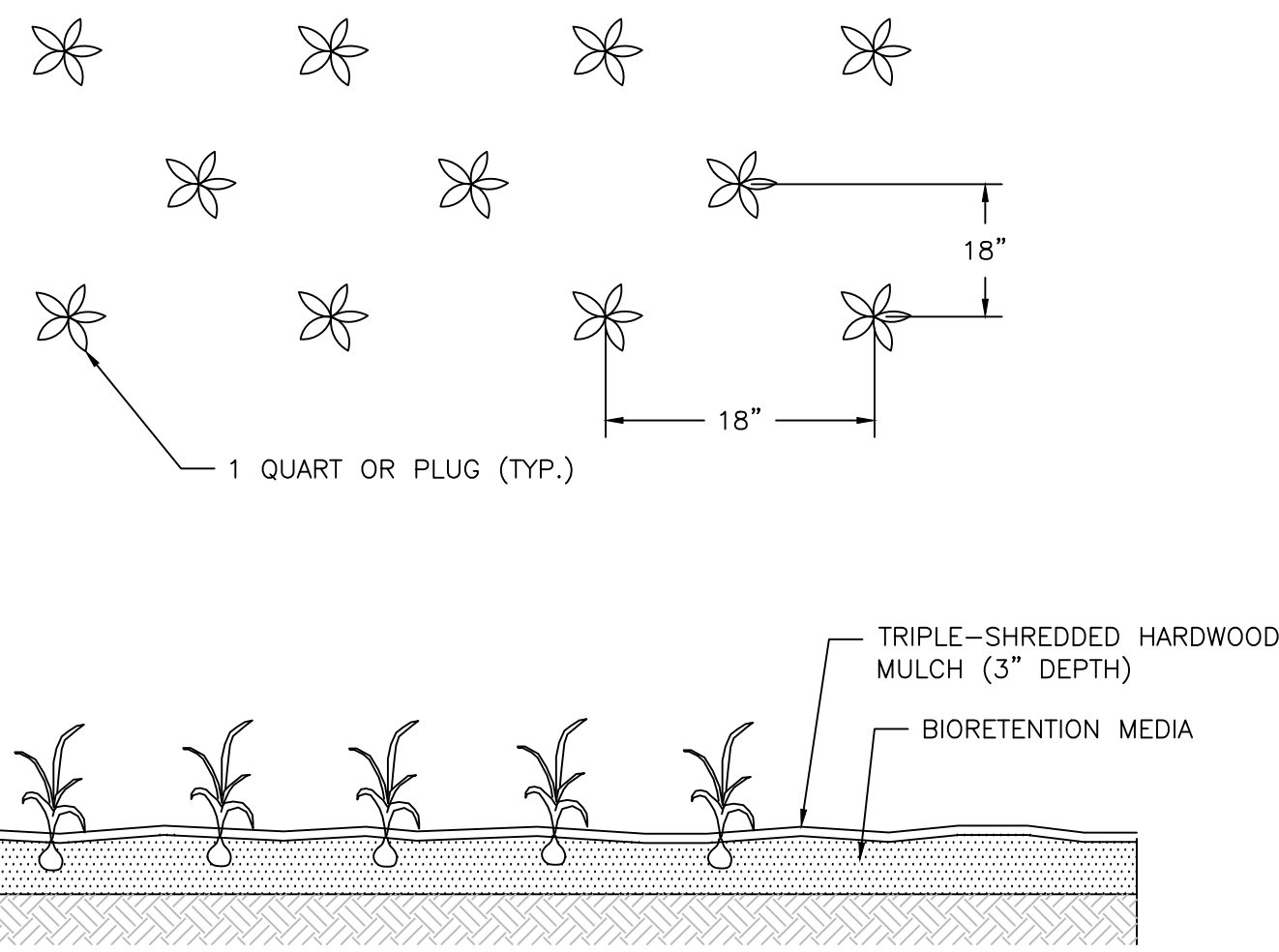

2 HERBACEOUS PLUG PLANTING DETAIL
DT-1 N.T.S.

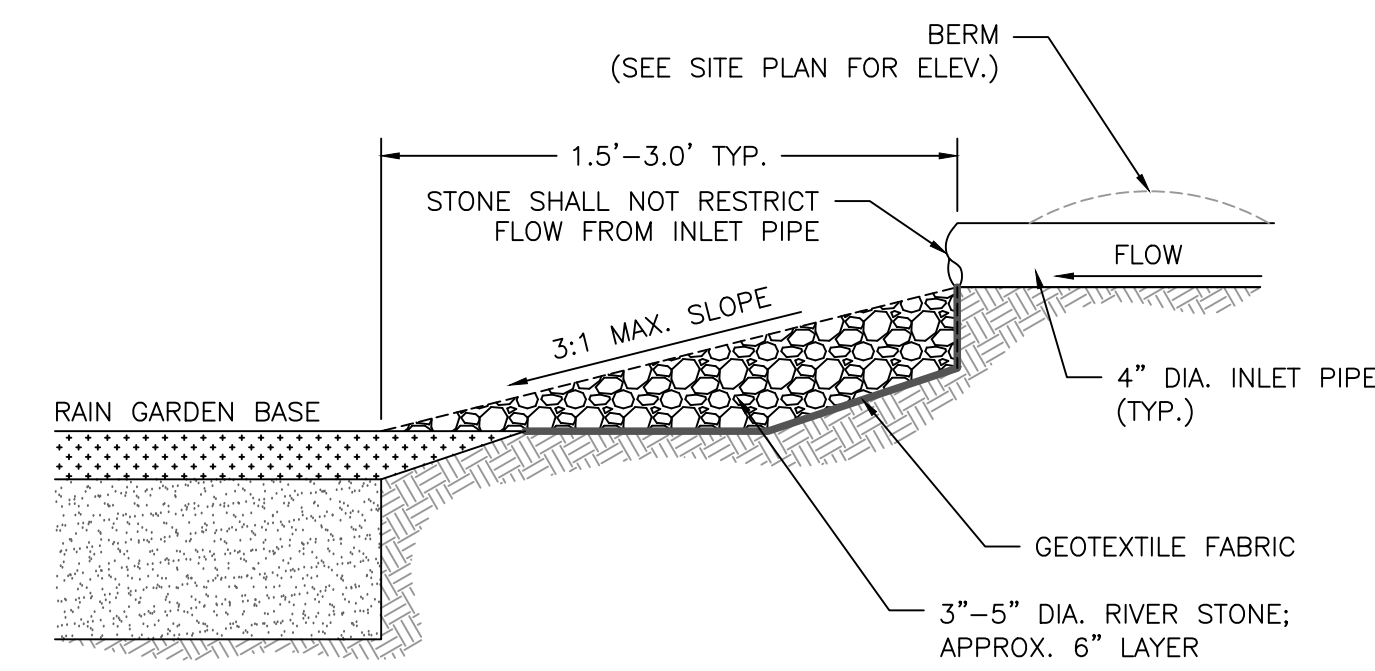

3 INLET PROTECTION CROSS-SECTION
DT-1 N.T.S.

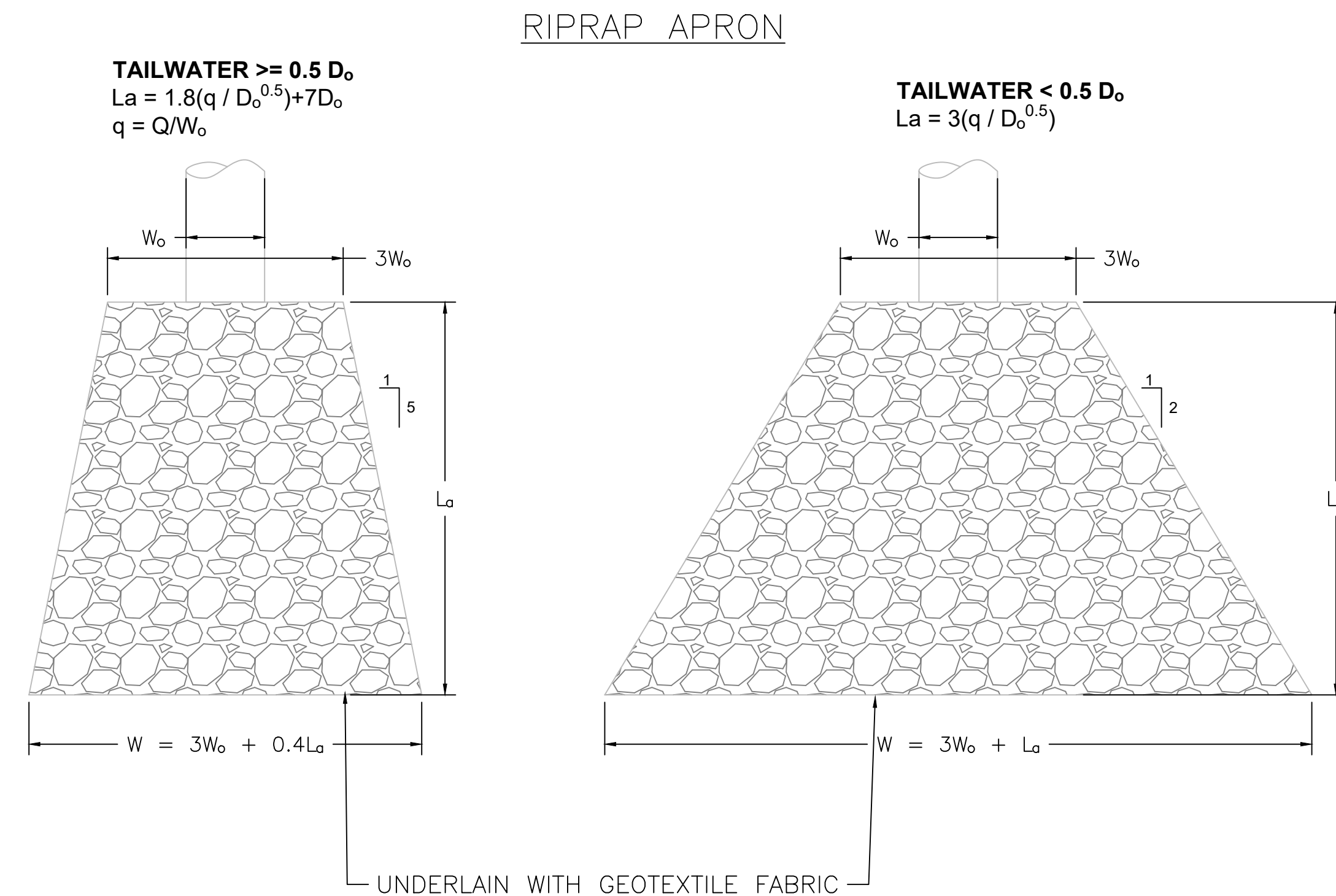

4 RIPRAP APRON DETAIL
DT-1 N.T.S.

CHRISTOPHER C. OBROPTA, Ph.D., P.E.
 PROFESSIONAL ENGINEER - NJ LICENSE # 37532

DATE: 06/26/24
 APPROVED: [Signature]
 CHECKED: [Signature]
 DRAWN: [Signature]

PLAN REVISIONS

No.	DATE	DESCRIPTION

DRAFT

FLANDERS DRIVE DEVELOPMENT
 GREEN INFRASTRUCTURE IMPLEMENTATION PROJECT
 FRANDERS DRIVE, HILLSBOROUGH TOWNSHIP
 SOMERSET COUNTY, NJ

BIORETENTION BASIN DETAILS

RUTGERS
 New Jersey Agricultural
 Experiment Station

14 COLLEGE FARM ROAD, NEW BRUNSWICK, NJ

SHEET NAME
 DT-1

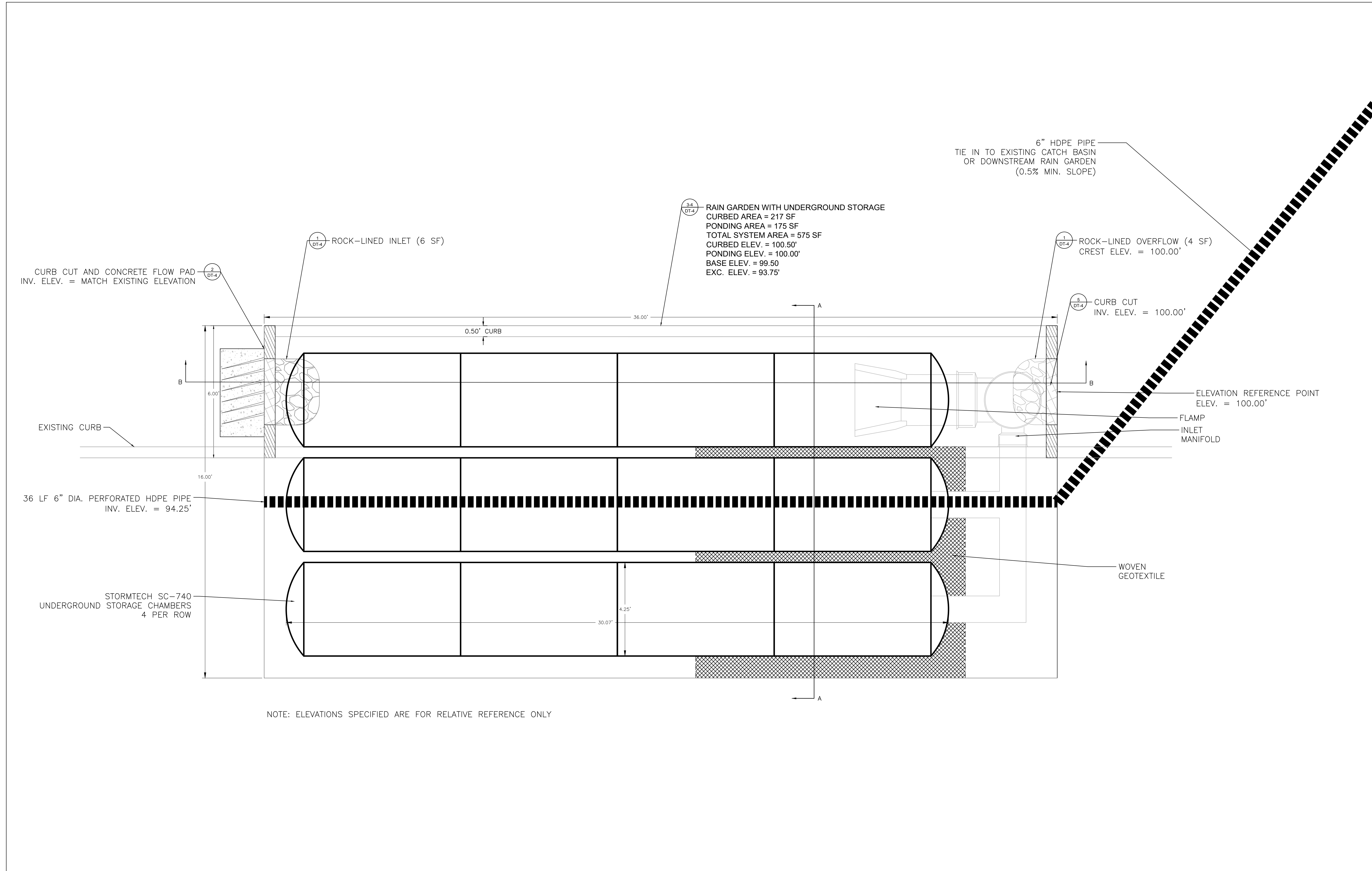

3/4 DT-4 RAIN GARDEN WITH UNDERGROUND STORAGE
 CURBED AREA = 217 SF
 PONDING AREA = 175 SF
 TOTAL SYSTEM AREA = 575 SF
 CURBED ELEV. = 100.50'
 PONDING ELEV. = 100.00'
 BASE ELEV. = 99.50
 EXC. ELEV. = 93.75'

6" HDPE PIPE
 TIE IN TO EXISTING CATCH BASIN
 OR DOWNSTREAM RAIN GARDEN
 (0.5% MIN. SLOPE)

1 DT-4 ROCK-LINED OVERFLOW (4 SF)
 CREST ELEV. = 100.00'

5 DT-4 CURB CUT
 INV. ELEV. = 100.00'

ELEVATION REFERENCE POINT
 ELEV. = 100.00'

FLAMP
 INLET
 MANIFOLD

WOVEN
 GEOTEXTILE

2 DT-4 CURB CUT AND CONCRETE FLOW PAD
 INV. ELEV. = MATCH EXISTING ELEVATION

36 LF 6" DIA. PERFORATED HDPE PIPE
 INV. ELEV. = 94.25'

STORMTECH SC-740
 UNDERGROUND STORAGE CHAMBERS
 4 PER ROW

NOTE: ELEVATIONS SPECIFIED ARE FOR RELATIVE REFERENCE ONLY

1 DT-2 STORMWATER PLANTER WITH STORMTECH STORAGE PLAN
 N.T.S.

CHRISTOPHER C. OBROPTA, Ph.D., P.E.
 PROFESSIONAL ENGINEER - NJ LICENSE # 37552

PLAN REVISIONS
 No. DATE DESCRIPTION

FLANDERS DRIVE DEVELOPMENT
 GREEN INFRASTRUCTURE IMPLEMENTATION PROJECT
 FRANDERS DRIVE, HILLSBOROUGH TOWNSHIP
 SOMERSET COUNTY, NJ

RUTGERS
 New Jersey Agricultural
 Experiment Station

SHEET NAME
 DT-2

DRAFT

DRAWN
 A/W

CHECKED
 M/L

APPROVED
 C/O

DATE
 06/26/2024

DATE
 XXXXXX

DATE
 XXXXXX

DATE
 XXXXXX

DATE
 XXXXXX

DATE
 XXXXXX

DATE
 XXXXXX

DATE
 XXXXXX

DATE
 XXXXXX

DATE
 XXXXXX

DATE
 XXXXXX

DATE
 XXXXXX

DATE
 XXXXXX

DATE
 XXXXXX

DATE
 XXXXXX

DATE
 XXXXXX

DATE
 XXXXXX

DATE
 XXXXXX

DATE
 XXXXXX

DATE
 XXXXXX

DATE
 XXXXXX

DATE
 XXXXXX

DATE
 XXXXXX

DATE
 XXXXXX

DATE
 XXXXXX

DATE
 XXXXXX

DATE
 XXXXXX

DATE
 XXXXXX

DATE
 XXXXXX

DATE
 XXXXXX

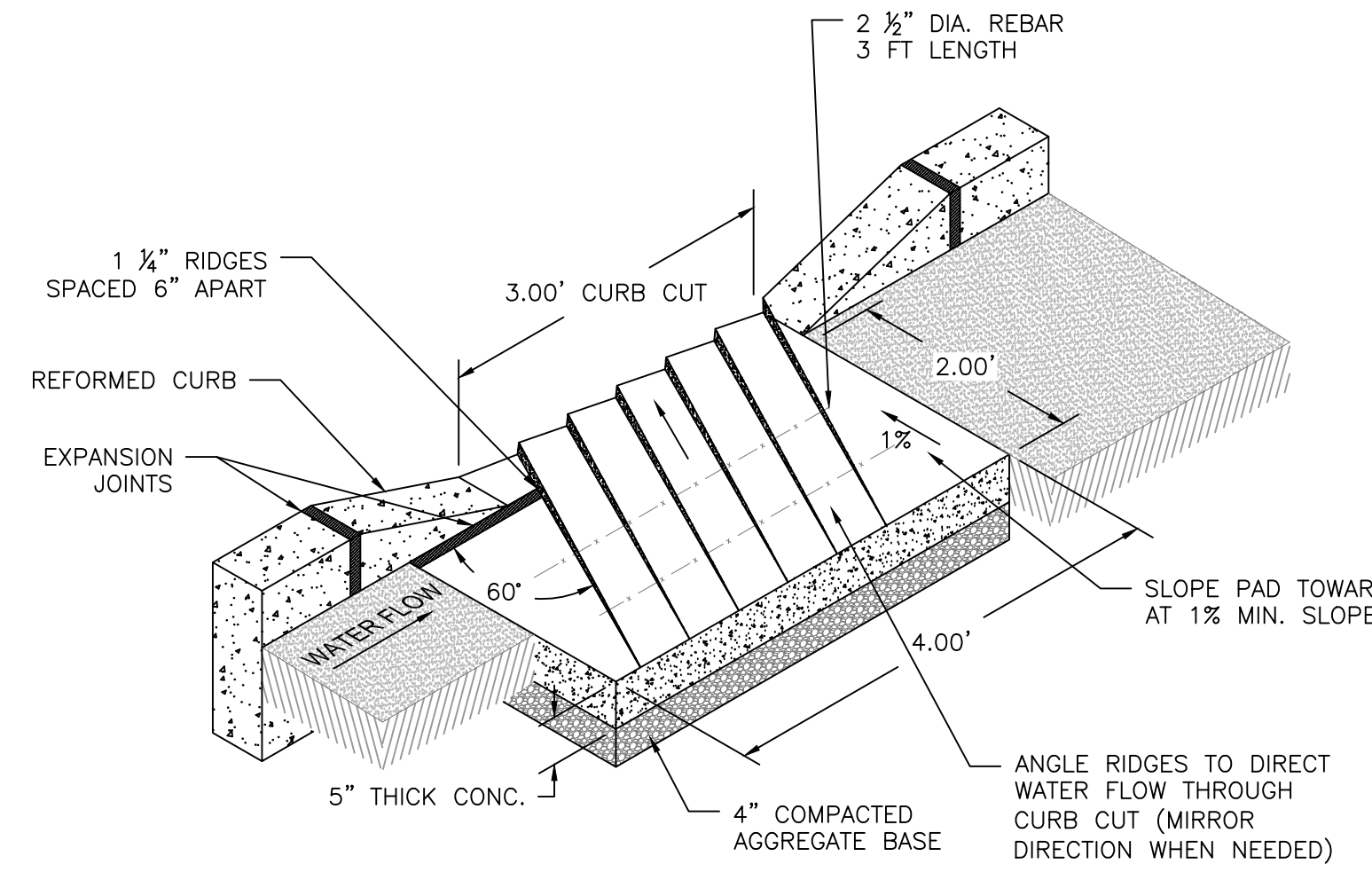
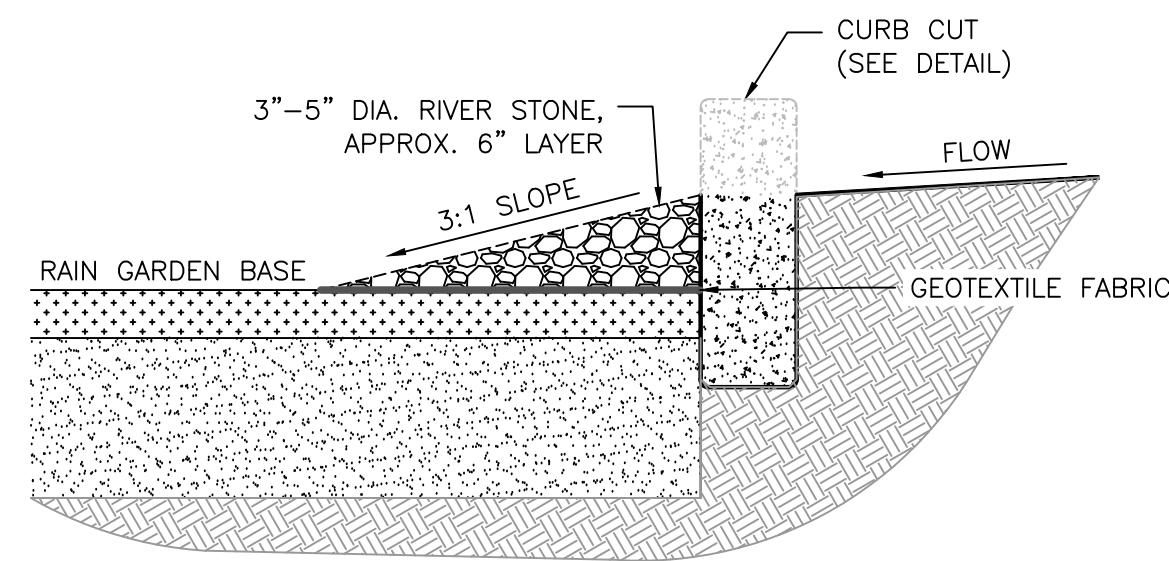

1 INLET/OUTLET CURB CUT PROTECTION
DT-3 N.T.S.

2 CONCRETE FLOW PAD DETAIL
DT-3 N.T.S.

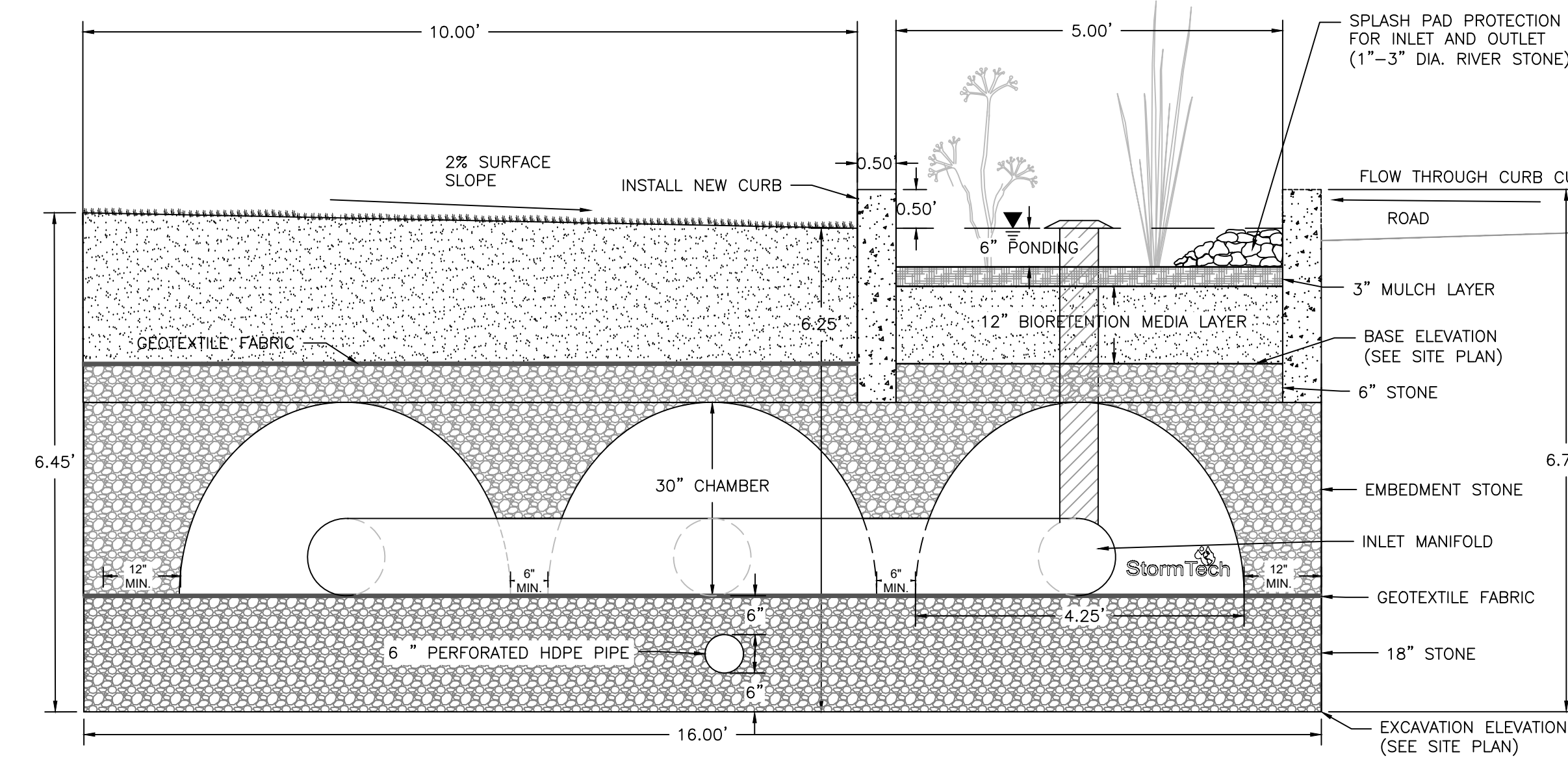

3 STORMWATER PLANTER WITH STORMTECH STORAGE [A-A]
DT-3 N.T.S.

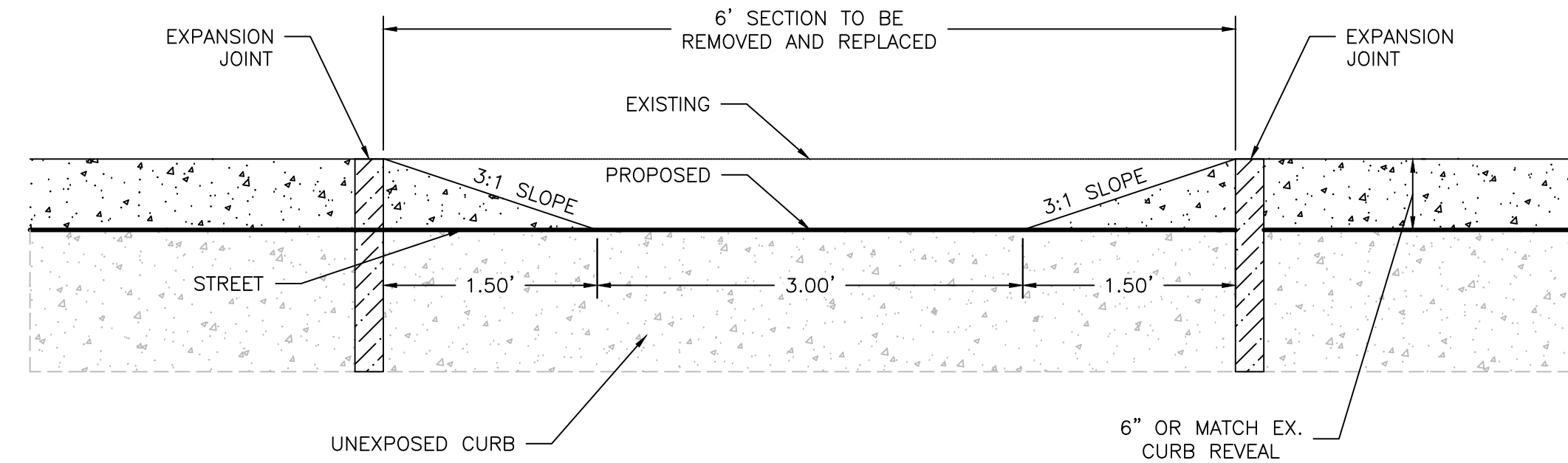

5 CURB CUT CROSS-SECTION
DT-3 N.T.S.

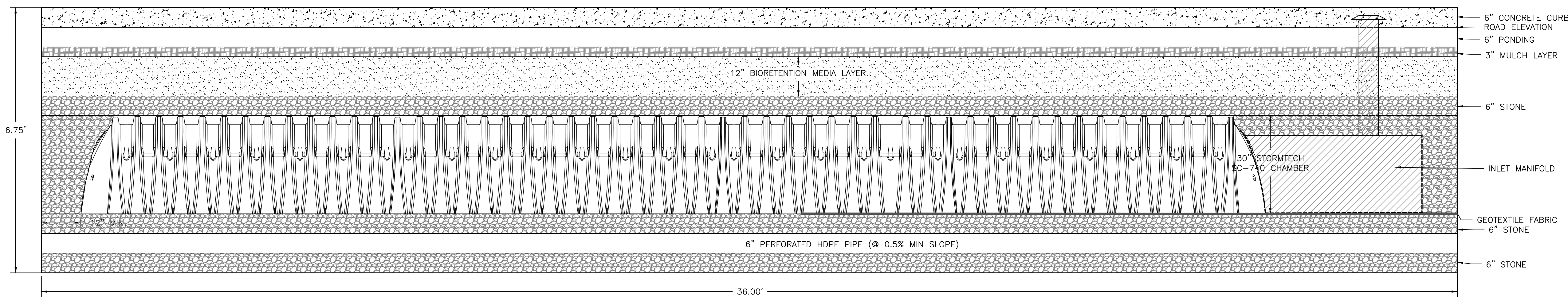

4 STORMWATER PLANTER CROSS SECTION (LONGITUDINAL) [B-B]
DT-3 N.T.S.

GENERAL CONSTRUCTION NOTES:

- REFER TO SITE PLAN FOR ALL ELEVATIONS, INVERTS, DIMENSIONS, AND SHAPE OF THE PROJECT.
- ALL WORK MUST MEET THE STANDARDS OF THE ENGINEER BEFORE PAYMENT. ADDITIONAL WORK AND TESTING WILL BE NECESSARY IF STANDARDS ARE NOT SUFFICED.
- THE APPROVAL OF MATERIALS SHALL BE DONE BY THE PROJECT ENGINEER/LANDSCAPE ARCHITECT.
- THE CONTRACTOR SHALL HAVE A PRE-CONSTRUCTION MEETING WITH THE PROJECT ENGINEER PRIOR TO ANY WORK ON SITE.
- THE CONTRACTOR SHALL VERIFY ALL INFORMATION PRIOR TO MOBILIZATION INCLUDING ELEVATIONS AND LOCATIONS OF EXISTING UTILITIES.
- THE CONTRACTOR SHALL PERFORM REQUIRED TESTING TO DETERMINE SOIL PERMEABILITY AND SEASONAL HIGH WATER TABLE ELEVATION AT THE SITE TO VERIFY INFILTRATION CAPABILITIES FOR SYSTEMS DESIGNED TO INFILTRATE. TESTING SHALL BE DONE PRIOR TO EXCAVATION AND INSTALLATION OF THE PROPOSED PROJECTS. PROJECT ENGINEER SHALL BE PRESENT DURING TESTING AND SHALL BE INFORMED OF THE RESULTS. THE TESTED INFILTRATION RATE SHALL BE AT LEAST 0.5 IN/HR OR 50 % OF THE HYDRAULIC CONDUCTIVITY (D3385).
- THE CONTRACTOR SHALL NOTIFY THE ENGINEER IMMEDIATELY IF ANY FIELD CONDITIONS DIFFER MATERIALLY FROM THOSE REPRESENTED ON THESE DRAWINGS AND THE SPECIFICATIONS OR IF, IN THE CONTRACTOR'S OPINION, SAID CONDITIONS CONFLICT WITH THE DESIGNS SHOWN HEREON.
- THE CONTRACTOR SHALL PERFORM ALL WORK IN CONFORMANCE WITH THE NJDOT STANDARD SPECIFICATIONS FOR ROAD AND BRIDGE CONSTRUCTION, 2019 OR LATEST VERSION.
- THE CONTRACTOR SHALL AVOID DISTURBING EXISTING AREAS OUTSIDE SPECIFIED LIMIT OF WORK. ANY DISTURBANCE TO SIDEWALKS, LANDSCAPED VEGETATION, AND TREES MUST BE COORDINATED WITH THE PROPERTY OWNER.
- THE CONTRACTOR IS TO RESTORE ALL DISTURBED AREAS OUTSIDE PROPOSED CHANGES TO ORIGINAL CONDITIONS AFTER INSTALLATION.
- THE CONTRACTOR SHALL HAVE ALL UTILITIES MARKED BEFORE ANY EXCAVATION. IF ANY UTILITIES INTERFERE WITH THE PROJECT, THE CONTRACTOR SHALL NOTIFY THE ENGINEER.
- THE CONTRACTOR SHALL ESTABLISH ALL ELEVATIONS AND LINES AS SHOWN IN THE SITE PLAN FOR REVIEW BY THE ENGINEER BEFORE ANY CONSTRUCTION BEGINS.
- THE CONTRACTOR SHALL AVOID OVER COMPACTING THE EXISTING MATERIALS IN ORDER TO AVOID POOR INFILTRATION OR SHORT LIFETIME OF THE SYSTEM.
- THE CONTRACTOR SHALL VERIFY THAT THE SUBGRADE IS CONSISTENT WITH LINE, GRADE, AND ELEVATIONS AS INDICATED IN THE SITE PLAN. ANY AREAS SHOWING EROSION OR POTENTIAL PONDING SHALL BE REGRADED BEFORE SUBBASE INSTALLATION.
- THE CONTRACTOR SHALL DISCUSS ANY MODIFICATIONS TO THE PROJECT WITH THE ENGINEER AND PROPERTY OWNER BEFORE ACTION IS TAKEN.
- THE CONTRACTOR SHALL EXCAVATE TO THE ELEVATIONS ON THE SITE PLAN AND DISPOSE OF ANY EXCESS MATERIALS.

STORMWATER PLANTER CONSTRUCTION NOTES:

- THE STRUCTURAL WALL SHALL BE 6" ABOVE SIDEWALK AS A SAFETY PRECAUTION. FOR A CURB-SIDE PLANTER, THE STRUCTURAL WALL ADJACENT TO THE ROADWAY SHALL BE LEVEL WITH THE EXISTING CURB. THE RISE OF THE STRUCTURAL WALL SHALL HAVE A 3:1 SLOPE TO ADJACENT CURB LINES. AS AN ALTERNATIVE, A FENCE (MIN 18" HIGH) MAY BE INSTALLED AROUND THE PLANTER.
- STORMWATER PLANTER SHALL BE STAKED OUT AND APPROVED BY ENGINEER PRIOR TO CONCRETE POURING.
- SEPARATION FABRIC SHALL BE LAID PRIOR TO BACKFILLING STORMWATER PLANTER.
- STORAGE LAYER AND COMPACTED AGGREGATE LAYER SHALL BE COMPRISED OF NO. 57 CLEAN, WASHED STONE.
- CHOKER COURSE SHALL BE COMPRISED OF 3/8" PEA GRAVEL.
- STRUCTURAL WALL SHALL BE A DEEP CONCRETE CURB IN CONFORMANCE WITH THE NJDOT STANDARD SPECIFICATIONS FOR ROAD AND BRIDGE CONSTRUCTION, 2019 OR LATEST VERSION.
- THE CONTRACTOR SHALL ONLY USE CONCRETE WITH 4,500 PSI STRENGTH.
- STONE PROTECTION DIMENSIONS ARE TYPICAL AND MAY VARY PER SITE. CONSULT THE ENGINEER AND SITE PLAN FOR DIMENSIONS ON A PER SITE BASIS.
- STONE PROTECTION SHALL SLOPE TO PLANTER BASE.
- INLET AND OUTLET PROTECTION SHALL BE UNDERLAIN WITH GEOTEXTILE FABRIC.
- INLETS AND OUTLETS SHALL NOT INHIBIT THE FLOW OF WATER.
- PLANTER SHALL BE CONSTRUCTED TO DIMENSIONS INDICATED ON THE SITE PLAN.
- MAX COVER OVER TOP OF PIPES IF PRESENT IS 4 FT. UNLESS APPROVED BY ENGINEER.
- NON-DYED, TRIPLE-SHREDDED HARDWOOD MULCH OR APPROVED ALTERNATIVE SHALL BE USED.
- THE CONTRACTOR SHALL EXCAVATE TO THE EXCAVATION DEPTH SHOWN ON THE SITE PLANS.
- CONTRACTOR SHALL NOTIFY ENGINEER IMMEDIATELY IF ANY EVIDENCE OF HIGH WATER TABLE, CLAY SOILS, OR POOR DRAINAGE IS OBSERVED.
- THE SOIL BED MATERIAL MUST CONSIST OF THE FOLLOWING MIX, BY WEIGHT: 85 TO 95% SAND, WITH NO MORE THAN 25% OF THE SAND AS FINE OR VERY FINE SANDS; NO MORE THAN 15% SILT AND CLAY WITH 2% TO 5% CLAY CONTENT. THE ENTIRE MIX MUST THEN BE AMENDED WITH 3 TO 7% ORGANICS, BY WEIGHT.
- BIORETENTION MEDIA MAY BE CREATED WITH A 70% SAND AND 30% COMPOST MIXTURE IF IT CONFORMS TO THE ABOVE. SAND SHALL AT THE MINIMUM CONFORM TO THE SIEVE ANALYSIS FOR CONCRETE AGGREGATE SAND (ASTM C-33). USGA TEE/GREEN SIEVE GRADATION MIX IS PREFERABLE WHERE AVAILABLE.
- PRIOR TO BACKFILLING, THE CONTRACTOR SHALL SCARIFY NATIVE SOIL TO PROMOTE INFILTRATION INTO UNDERLYING SUBGRADE.
- CONTRACTOR SHALL OBTAIN ENGINEER APPROVAL PRIOR TO BACKFILLING WITH BIORETENTION MEDIA.
- ALL BIORETENTION MEDIA SHALL BE PLACED FROM THE SIDES OF THE FACILITIES, AND IN NO EVENT SHALL ANY TRACKED OR WHEELED EQUIPMENT BE PERMITTED TO CROSS EXCAVATED SECTIONS.
- THE CONTRACTOR SHALL INSTALL THE OVERFLOW PIPE IF SPECIFIED IN SITE PLANS PRIOR TO BACKFILLING.

STORMTECH CHAMBER CONSTRUCTION NOTES:

- STORMTECH SC-740 CHAMBER OR APPROVED EQUIVALENT.
- FOLLOW ALL INSTALLATION GUIDANCE PROVIDED BY STORMTECH OR APPROVED EQUIVALENT VENDOR.

CHRISTOPHER C. OBROPTA, Ph.D., P.E.
PROFESSIONAL ENGINEER - NJ LICENSE # 9752

PLAN REVISIONS
No. DATE DESCRIPTION

FLANDERS DRIVE DEVELOPMENT
GREEN INFRASTRUCTURE IMPLEMENTATION PROJECT
FRANDERS DRIVE, HILLSBOROUGH TOWNSHIP
SOMERSET COUNTY, NJ
STORMWATER PLANTER WITH STORAGE
DETAILS CONT.

RUTGERS
New Jersey Agricultural
Experiment Station
14 COLLEGE FARM ROAD, NEW BRUNSWICK, NJ

SHEET NAME
DT-3

DATE: XXXXXX
 APPROVED: [Signature]
 CHECKED: [Signature]
 DRAWN: [Signature]
 DATE: 06/26/24

DRAFT

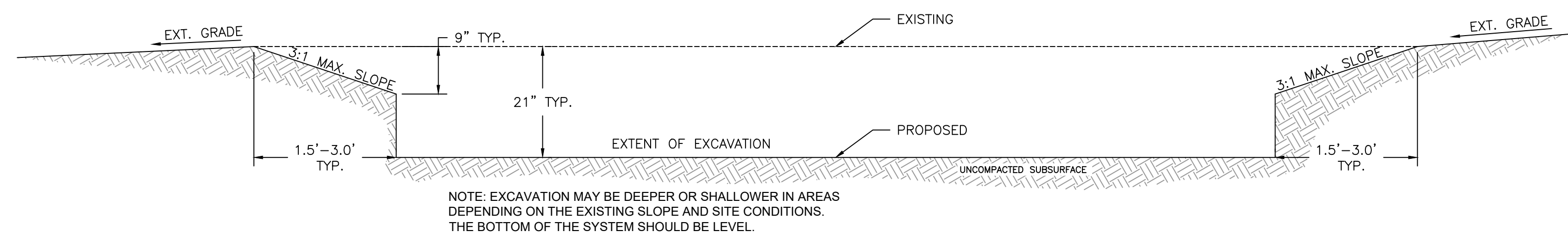

1 RAIN GARDEN EXCAVATION SECTION
DT-4 N.T.S.

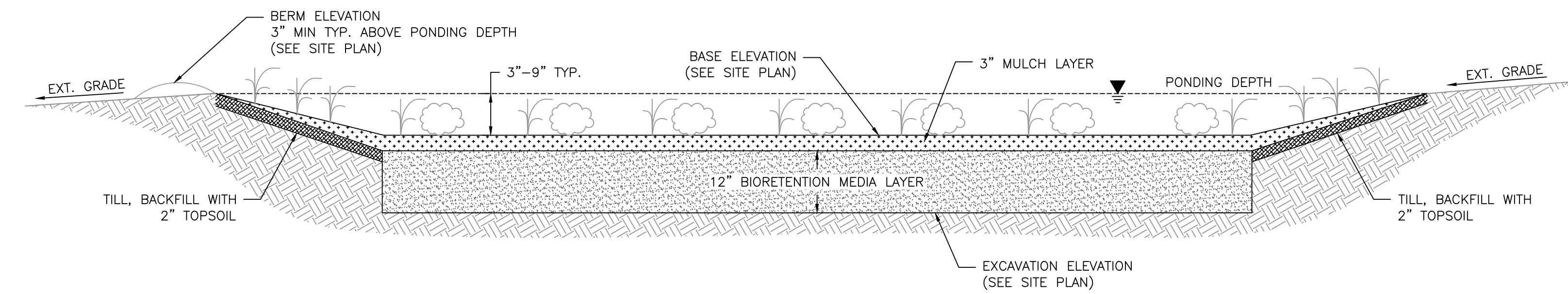

2 RAIN GARDEN CROSS-SECTION
DT-4 N.T.S.

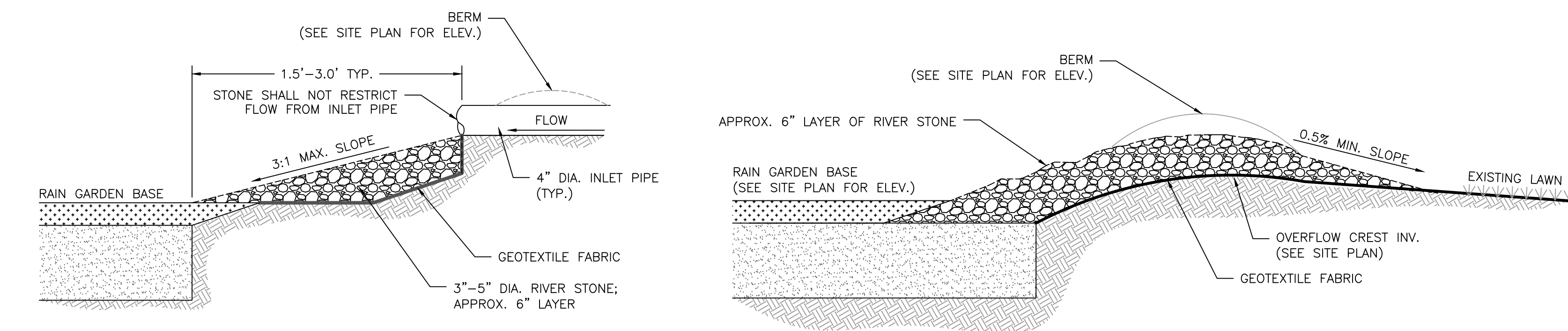

3 INLET PROTECTION CROSS-SECTION
DT-4 N.T.S.

4 ROCK-LINED OVERFLOW DETAIL
DT-4 N.T.S.

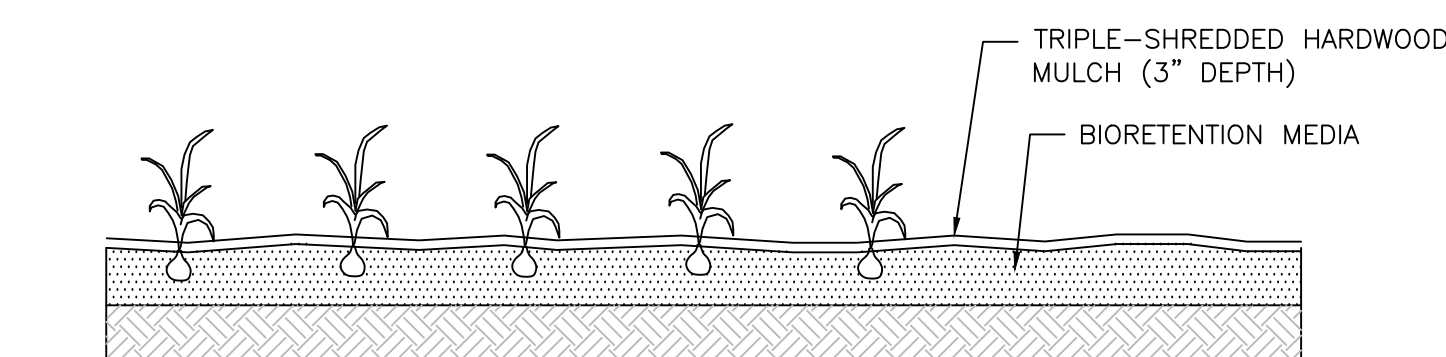
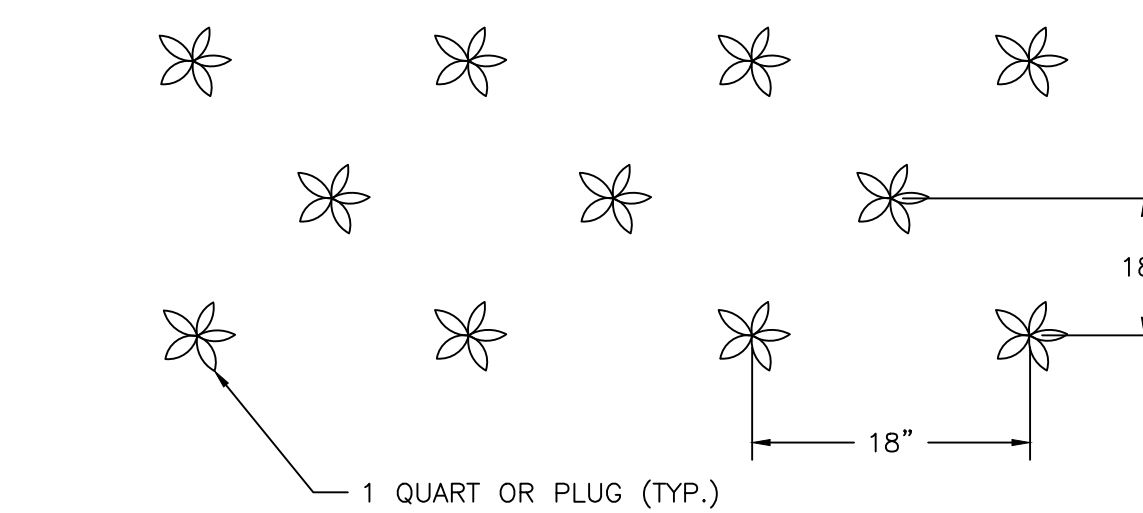

5 HERBACEOUS PLUG PLANTING DETAIL
DT-4 N.T.S.

GENERAL CONSTRUCTION NOTES:

- REFER TO SITE PLAN FOR ALL ELEVATIONS, INVERTS, DIMENSIONS, AND SHAPE OF THE PROJECT.
- ALL WORK MUST MEET THE STANDARDS OF THE ENGINEER BEFORE PAYMENT. ADDITIONAL WORK AND TESTING WILL BE NECESSARY IF STANDARDS ARE NOT SUFFICED.
- THE APPROVAL OF MATERIALS SHALL BE DONE BY THE PROJECT ENGINEER/LANDSCAPE ARCHITECT.
- THE CONTRACTOR SHALL HAVE A PRE-CONSTRUCTION MEETING WITH THE PROJECT ENGINEER PRIOR TO ANY WORK ON SITE.
- THE CONTRACTOR SHALL VERIFY ALL INFORMATION PRIOR TO MOBILIZATION INCLUDING ELEVATIONS AND LOCATIONS OF EXISTING UTILITIES.
- THE CONTRACTOR SHALL PERFORM REQUIRED TESTING TO DETERMINE SOIL PERMEABILITY AND SEASONAL HIGH WATER TABLE ELEVATION AT THE SITE TO VERIFY INFILTRATION CAPABILITIES FOR SYSTEMS DESIGNED TO INFILTRATE. TESTING SHALL BE DONE PRIOR TO EXCAVATION AND INSTALLATION OF THE PROPOSED PROJECTS. PROJECT ENGINEER SHALL BE PRESENT DURING TESTING AND SHALL BE INFORMED OF THE RESULTS. THE TESTED INFILTRATION RATE SHALL BE AT LEAST 0.5 IN/HR OR 50 % OF THE HYDRAULIC CONDUCTIVITY (D3385).
- THE CONTRACTOR SHALL NOTIFY THE ENGINEER IMMEDIATELY IF ANY FIELD CONDITIONS DIFFER MATERIALLY FROM THOSE REPRESENTED ON THESE DRAWINGS AND THE SPECIFICATIONS OR IF, IN THE CONTRACTOR'S OPINION, SAID CONDITIONS CONFLICT WITH THE DESIGNS SHOWN HEREON.
- THE CONTRACTOR SHALL PERFORM ALL WORK IN CONFORMANCE WITH THE NJDOT STANDARD SPECIFICATIONS FOR ROAD AND BRIDGE CONSTRUCTION, 2019 OR LATEST VERSION.
- THE CONTRACTOR SHALL AVOID DISTURBING EXISTING AREAS OUTSIDE SPECIFIED LIMIT OF WORK. ANY DISTURBANCE TO SIDEWALKS, LANDSCAPED VEGETATION, AND TREES MUST BE COORDINATED WITH THE PROPERTY OWNER.
- THE CONTRACTOR IS TO RESTORE ALL DISTURBED AREAS OUTSIDE PROPOSED CHANGES TO ORIGINAL CONDITIONS AFTER INSTALLATION.
- THE CONTRACTOR SHALL HAVE ALL UTILITIES MARKED BEFORE ANY EXCAVATION. IF ANY UTILITIES INTERFERE WITH THE PROJECT, THE CONTRACTOR SHALL NOTIFY THE ENGINEER.
- THE CONTRACTOR SHALL ESTABLISH ALL ELEVATIONS AND LINES AS SHOWN IN THE SITE PLAN FOR REVIEW BY THE ENGINEER BEFORE ANY CONSTRUCTION BEGINS.
- THE CONTRACTOR SHALL AVOID OVER COMPACTING THE EXISTING MATERIALS IN ORDER TO AVOID POOR INFILTRATION OR SHORT LIFETIME OF THE SYSTEM.
- THE CONTRACTOR SHALL VERIFY THAT THE SUBGRADE IS CONSISTENT WITH LINE, GRADE, AND ELEVATIONS AS INDICATED IN THE SITE PLAN. ANY AREAS SHOWING EROSION OR POTENTIAL PONDING SHALL BE REGRADED BEFORE SUBBASE INSTALLATION.
- THE CONTRACTOR SHALL DISCUSS ANY MODIFICATIONS TO THE PROJECT WITH THE ENGINEER AND PROPERTY OWNER BEFORE ACTION IS TAKEN.
- THE CONTRACTOR SHALL EXCAVATE TO THE ELEVATIONS ON THE SITE PLAN AND DISPOSE OF ANY EXCESS MATERIALS.

RAIN GARDEN CONSTRUCTION NOTES:

- RIVER STONE PROTECTION DIMENSIONS ARE TYPICAL AND MAY VARY PER SITE. CONSULT THE ENGINEER AND SITE PLAN FOR DIMENSIONS ON A PER SITE BASIS.
- RIVER STONE PROTECTION SHALL SLOPE TO RAIN GARDEN BASE.
- INLET AND OUTLET PROTECTION SHALL BE UNDERLAIN WITH GEOTEXTILE FABRIC.
- INLETS AND OUTLETS SHALL NOT INHIBIT THE FLOW OF WATER
- 3-5 INCH RIVER STONE SHALL BE USED FOR INLET/OUTLET PROTECTION.
- RAIN GARDEN SHALL BE CONSTRUCTED TO DIMENSIONS INDICATED ON THE SITE PLAN.
- NON-DYED, TRIPLE-SHREDDED HARDWOOD MULCH OR APPROVED ALTERNATIVE SHALL BE USED.
- PLANTING OF RAIN GARDEN AND SLOPED BERM SHALL BE COMPLETED AS INDICATED ON THE SITE PLAN.
- MAX COVER OVER TOP OF PIPES IF PRESENT IS 4 FT. UNLESS APPROVED BY ENGINEER.
- THE CONTRACTOR SHALL EXCAVATE LOWER THAN THE BASE ELEVATION TO THE EXCAVATION DEPTH SHOWN ON THE SITE PLANS. THE SLOPES OF THE RAIN GARDEN SHALL BE AT A 3:1 MAXIMUM TO BASE ELEVATION THEN A VERTICAL DROP TO EXCAVATION DEPTH.
- THE SOIL BED MATERIAL MUST CONSIST OF THE FOLLOWING MIX, BY WEIGHT: 85 TO 95% SAND, WITH NO MORE THAN 25% OF THE SAND AS FINE OR VERY FINE SANDS; NO MORE THAN 15% SILT AND CLAY WITH 2% TO 5% CLAY CONTENT. THE ENTIRE MIX MUST THEN BE AMENDED WITH 3 TO 7% ORGANICS, BY WEIGHT.
- BIORETENTION MEDIA MAY BE CREATED WITH A 70% SAND AND 30% COMPOST MIXTURE IF IT CONFORMS TO THE ABOVE. SAND SHALL AT THE MINIMUM CONFORM TO THE SIEVE ANALYSIS FOR CONCRETE AGGREGATE SAND (ASTM C-33). USGA TEE/GREEN SIEVE GRADATION MIX IS PREFERABLE WHERE AVAILABLE.
- CONTRACTOR SHALL NOTIFY ENGINEER IMMEDIATELY IF ANY EVIDENCE OF HIGH WATER TABLE, CLAY SOILS, OR POOR DRAINAGE IS OBSERVED AND NO UNDERDRAIN IS SPECIFIED IN THE PLANS.
- PRIOR TO BACKFILLING, THE CONTRACTOR SHALL SCARIFY NATIVE SOIL TO PROMOTE INFILTRATION INTO UNDERLYING SUBGRADE.
- CONTRACTOR SHALL OBTAIN ENGINEER APPROVAL PRIOR TO BACKFILLING WITH BIORETENTION MEDIA.
- THE BIORETENTION MEDIA SHALL BE LEVEL OVER THE NATIVE SUBGRADE TO ENSURE PROPER DRAINAGE.
- ALL BIORETENTION MEDIA SHALL BE PLACED FROM THE SIDES OF THE FACILITIES, AND IN NO EVENT SHALL ANY TRACKED OR WHEELED EQUIPMENT BE PERMITTED TO CROSS EXCAVATED SECTIONS.
- THE CONTRACTOR SHALL INSTALL THE OVERFLOW PIPE IF SPECIFIED IN SITE PLANS PRIOR TO BACKFILLING WITH BIORETENTION MEDIA.

PLANTING AND LANDSCAPING CONSTRUCTION NOTES:

- THE LANDSCAPE ARCHITECT OR ENGINEER SHALL INSPECT ALL PLANTING AREAS BEFORE ANY TOPSOILING OR PLANTING IS BEGUN TO ENSURE THAT ADEQUATE DRAINAGE EXISTS. IF ANY AREAS TO BE LANDSCAPED SHOW EVIDENCE OF POOR DRAINAGE, THE LANDSCAPE ARCHITECT SHALL NOTIFY THE OWNER IMMEDIATELY FOR CORRECTIVE ACTION
- THE LANDSCAPE ARCHITECT OR ENGINEER SHALL APPROVE ALL PLANT MATERIAL AND STAKED PLANT LOCATIONS PRIOR TO INSTALLATION.
- ALL PLANT MATERIALS SHALL CONFIRM TO THE AMERICAN ASSOCIATION OF NURSERYMEN'S AMERICAN STANDARD FOR NURSERY STOCK (LATEST EDITION)
- ALL PLANT MATERIAL SHALL BE PLACED IN CONTINUOUS MULCHED BEDS 4" IN DEPTH. MULCH SHALL BE TRIPLE SHREDDED HARDWOOD OR APPROVED ALTERNATIVE.
- ALL PLANT MATERIAL SHALL BE AS SPECIFIED AND SHALL BE INSTALLED IN ACCORDANCE WITH THE DETAILS AND COMMENTS NOTED ON THE DRAWINGS.
- THE CONTRACTOR SHALL PROVIDE THE TOPSOIL FOR PLANTING ACCORDING TO THE PLANS AND DETAILS.
- PREPARED TOPSOIL FOR BACKFILLING AROUND TREE BALLS SHALL BE A MIXTURE OF VOLUME OF THE FOLLOWING MATERIALS IN QUANTITIES SPECIFIED: 1/3 COMPOST, 2/3 TOPSOIL BY VOLUME.
- SEED ALL REMAINING GRASS AREAS WITH TURF TYPE FALL FESCUE AND PERENNIAL RYEGRASS BLEND (LOFTS - SUMMER STRESS MIX II OR APPROVED EQUIVALENT). INSTALL AT A RATE OF 350 LBS. PER ACRE PER MANUFACTURERS SPECIFICATIONS.
- ANY UNDISTURBED AREA ON WHICH ACTIVITY HAS CEASED AND WHICH WILL REMAIN EXPOSED FOR MORE THAN 10 DAYS MUST BE SEEDED AND MULCHED IMMEDIATELY. DURING NON-GERMINATING PERIODS, MULCH MUST BE APPLIED AT THE REQUIRED RATES. DISTURBED AREAS WHICH ARE NOT AT FINISHED GRADE AND WHICH WILL BE REDISTURBED WITHIN 1 YEAR SHALL BE SEEDED AND MULCHED WITH A QUICK GROWING TEMPORARY SEEDING MIXTURE AND MULCH. DISTURBED AREAS WHICH ARE EITHER AT FINISHED GRADE OR WILL NOT BE REDISTURBED WITHIN 1 YEAR MUST BE SEEDED AND MULCHED WITH A PERMANENT SEED MIXTURE AND MULCH.
- DIVERSIONS, CHANNELS, SEDIMENTATION BASINS, SEDIMENT TRAPS, AND STOCKPILES MUST BE SEEDED AND MULCHED IMMEDIATELY.
- GRADED AREAS SHALL BE TEMPORARILY SEEDED AND MULCHED IMMEDIATELY FOLLOWING EARTH MOVING PROCEDURES. TEMPORARY SEED SHALL BE ANNUAL RYE GRASS APPLIED AT A RATE OF 3 LBS. PER 1000 SQ. FT.
- AFTER SEEDED, HAY OR STRAW MULCH MUST BE APPLIED AT A RATE OF AT LEAST 3.0 TONS PER ACRE. MULCH SHALL BE ANCHORED BY EITHER CRIMPING WITH A COULTER IMPLEMENT, OR BY STAPLING BIODEGRADABLE NETTING TO THE SURFACE.
- SITE PREPARATION TO UPLAND AREAS: APPLY 1 TON OF AGRICULTURAL-GRADE LIMESTONE PER ACRE PLUS 10-20-10 FERTILIZER AT THE RATE OF 500 LB. PER ACRE. WORK IN WHERE POSSIBLE. SEEDING OF DISTURBED UPLAND AREAS (BEYOND LIMITS OF RIPARIAN ENHANCEMENT AREA) TO BE DONE USING MIX OF FINE FESCUE AT 35 LBS/ACRE (PURE LIVE SEED) PLUS PERENNIAL RYEGRASS AT 15 LBS/ACRE (PURE LIVE SEED).
- TOPSOIL SHALL BE A CLEAN FRIABLE LOAM WITH SUFFICIENT ORGANIC CONTENT (2.75%) TO PROMOTE PLANT VIGOR. AMENDMENTS SHALL BE ADDED AS NEEDED TO IMPROVE DEFICIENT SOILS. TOPSOIL SHALL BE RETURNED AT A LOOSE DEPTH OF FIVE INCHES TO ALLOW FOR SETTLEMENT.
- ESTABLISH PERMANENT SEEDING AS SOON AS POSSIBLE AFTER FINAL GRADING IS COMPLETE. PERMANENT SEEDING SHALL BE SEED MIXTURE SPECIFIED.
- NATIVE SHRUBS, TREES, HERBACEOUS PLANTS, AND SEED ARE AVAILABLE AT PINELANDS NURSERY AND SUPPLY, PLEASANT RUN NURSERY, OR PREFERRED SUPPLIER.

CHRISTOPHER C. OBROPTA, Ph.D., P.E.
PROFESSIONAL ENGINEER - NJ LICENSE # 97532
DATE 06/26/2024
APPROVED
DRAWN
CHECKED

PLAN REVISIONS
No. DATE DESCRIPTION
DRAFT

FLANDERS DRIVE DEVELOPMENT
GREEN INFRASTRUCTURE IMPLEMENTATION PROJECT
FRANDERS DRIVE, HILLSBOROUGH TOWNSHIP
SOMERSET COUNTY, NJ
RAIN GARDEN AND PLANTING DETAILS

RUTGERS
New Jersey Agricultural
Experiment Station
14 COLLEGE FARM ROAD, NEW BRUNSWICK, NJ

SHEET NAME
DT-4

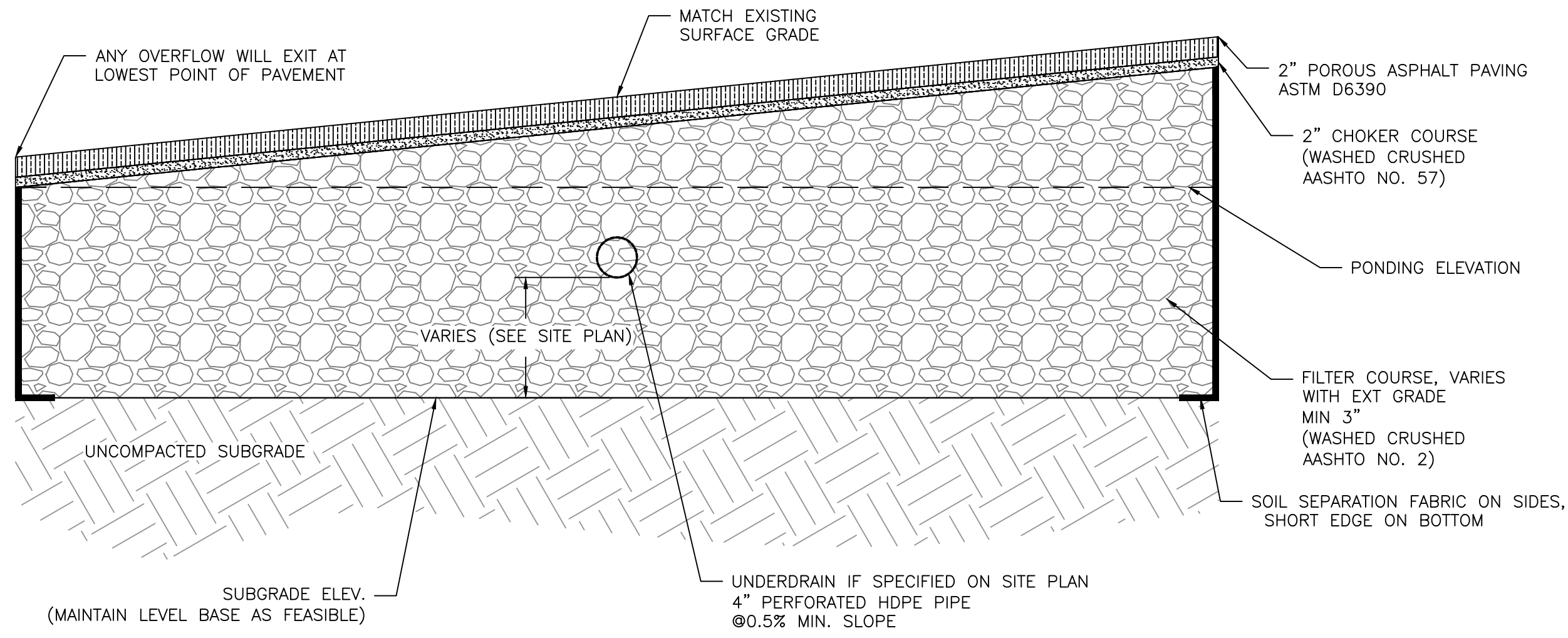

1 POROUS ASPHALT CROSS-SECTION
DT-5 N.T.S.

TABLE 901.03-1 STANDARD SIZES OF COARSE AGGREGATE

No.	NOMINAL SIZE	AMOUNTS FINER THAN EACH LABORATORY SIEVE, % BY WEIGHT														
		4"	3 1/2"	3"	2 1/2"	2"	1 1/2"	1"	3/4"	1/2"	3/8"	No. 4	No. 8	No. 16	No. 50	No. 100
1	3 1/2" - 1 1/2"	100	90-100		25-60		0-15		0-5							
2	2 1/2" - 1 1/2"			100	90-100	35-70	0-15		0-5							
3	2" - 1"				100	90-100	35-70	0-15		0-5						
4	1 1/2" - 3/4"					100	90-100	20-55	0-15		0-5					
5	1" - 1/2"						100	90-100	20-55	0-10	0-5					
57	1"-No. 4							100	95-100		25-60		0-10	0-5		
67	3/4" - No. 4								100	90-100		20-55	0-10	0-5		
7	1/2" - No. 4									100	90-100	40-70	0-15	0-5		
8	3/8" - No. 8										100	85-100	10-30	0-10	0-5	
9	No. 4 - No. 16											100	85-100	10-40	0-10	0-5
10	No. 4 - No. 200												100	85-100		10-30

2 NJDOT STANDARD SPECIFICATIONS FOR AGGREGATE
DT-5

GENERAL CONSTRUCTION NOTES:

- REFER TO SITE PLAN FOR ALL ELEVATIONS, INVERTS, DIMENSIONS, AND SHAPE OF THE PROJECT.
- ALL WORK MUST MEET THE STANDARDS OF THE ENGINEER BEFORE PAYMENT. ADDITIONAL WORK AND TESTING WILL BE NECESSARY IF STANDARDS ARE NOT SUFFICED.
- THE APPROVAL OF MATERIALS SHALL BE DONE BY THE PROJECT ENGINEER/LANDSCAPE ARCHITECT.
- THE CONTRACTOR SHALL HAVE A PRE-CONSTRUCTION MEETING WITH THE PROJECT ENGINEER PRIOR TO ANY WORK ON SITE.
- THE CONTRACTOR SHALL VERIFY ALL INFORMATION PRIOR TO MOBILIZATION INCLUDING ELEVATIONS AND LOCATIONS OF EXISTING UTILITIES.
- THE CONTRACTOR SHALL PERFORM REQUIRED TESTING TO DETERMINE SOIL PERMEABILITY AND SEASONAL HIGH WATER TABLE ELEVATION AT THE SITE TO VERIFY INFILTRATION CAPABILITIES FOR SYSTEMS DESIGNED TO INFILTRATE. TESTING SHALL BE DONE PRIOR TO EXCAVATION AND INSTALLATION OF THE PROPOSED PROJECTS. PROJECT ENGINEER SHALL BE PRESENT DURING TESTING AND SHALL BE INFORMED OF THE RESULTS. THE TESTED INFILTRATION RATE SHALL BE AT LEAST 0.5 IN/HR OR 50 % OF THE HYDRAULIC CONDUCTIVITY (D3385).
- THE CONTRACTOR SHALL NOTIFY THE ENGINEER IMMEDIATELY IF ANY FIELD CONDITIONS DIFFER MATERIALLY FROM THOSE REPRESENTED ON THESE DRAWINGS AND THE SPECIFICATIONS OR IF, IN THE CONTRACTOR'S OPINION, SAID CONDITIONS CONFLICT WITH THE DESIGNS SHOWN HEREON.
- THE CONTRACTOR SHALL PERFORM ALL WORK IN CONFORMANCE WITH THE NJDOT STANDARD SPECIFICATIONS FOR ROAD AND BRIDGE CONSTRUCTION, 2019 OR LATEST VERSION.
- THE CONTRACTOR SHALL AVOID DISTURBING EXISTING AREAS OUTSIDE SPECIFIED LIMIT OF WORK. ANY DISTURBANCE TO SIDEWALKS, LANDSCAPED VEGETATION, AND TREES MUST BE COORDINATED WITH THE PROPERTY OWNER.
- THE CONTRACTOR IS TO RESTORE ALL DISTURBED AREAS OUTSIDE PROPOSED CHANGES TO ORIGINAL CONDITIONS AFTER INSTALLATION.
- THE CONTRACTOR SHALL HAVE ALL UTILITIES MARKED BEFORE ANY EXCAVATION. IF ANY UTILITIES INTERFERE WITH THE PROJECT, THE CONTRACTOR SHALL NOTIFY THE ENGINEER.
- THE CONTRACTOR SHALL ESTABLISH ALL ELEVATIONS AND LINES AS SHOWN IN THE SITE PLAN FOR REVIEW BY THE ENGINEER BEFORE ANY CONSTRUCTION BEGINS.
- THE CONTRACTOR SHALL AVOID OVER COMPACTING THE EXISTING MATERIALS IN ORDER TO AVOID POOR INFILTRATION OR SHORT LIFETIME OF THE SYSTEM.
- THE CONTRACTOR SHALL VERIFY THAT THE SUBGRADE IS CONSISTENT WITH LINE, GRADE, AND ELEVATIONS AS INDICATED IN THE SITE PLAN. ANY AREAS SHOWING EROSION OR POTENTIAL PONDING SHALL BE REGRADED BEFORE SUBBASE INSTALLATION.
- THE CONTRACTOR SHALL DISCUSS ANY MODIFICATIONS TO THE PROJECT WITH THE ENGINEER AND PROPERTY OWNER BEFORE ACTION IS TAKEN.
- THE CONTRACTOR SHALL EXCAVATE TO THE ELEVATIONS ON THE SITE PLAN AND DISPOSE OF ANY EXCESS MATERIALS.

PERMEABLE PAVEMENT CONSTRUCTION NOTES:

- THE CONTRACTOR SHALL PLACE GEOTEXTILE FABRIC IN CONFORMANCE WITH MANUFACTURER'S STANDARDS. ALL ADJACENT FABRIC SHALL BE OVERLAPPED BY AT LEAST 16 INCHES. THE FABRIC SHALL BE SECURED AT LEAST FOUR FEET OUTSIDE OF THE EXCAVATED BASE. FABRIC SHALL NOT BE PLACED ON THE EXCAVATED BASE EXCEPT ON EDGES UNLESS AN UNDERDRAIN IS PRESENT.
- THE FILTER COURSE AGGREGATE SHALL BE INSTALLED IN 8 INCH MAXIMUM LIFTS TO A MAXIMUM OF 95% STANDARD PROCTOR COMPACTION (ASTM D698/AASHTO T99).
- CHOKER SHALL BE INSTALLED EVENLY OVER FILTER COURSE. THE CONTRACTOR SHALL NOTIFY THE ENGINEER FOR APPROVAL. CHOKER BASE SHALL BE AT LEAST TWO INCHES THICK. CHOKER, GRAVEL, AND STONE BASE AGGREGATE SHALL BE INSTALLED TO A MAXIMUM OF 95% STANDARD PROCTOR COMPACTION.
- SUBBASE COURSE DENSITIES SHALL BE APPROVED BY THE ENGINEER. ROLLING AND SHAPING SHALL RESUME UNTIL DENSITIES ARE ACCEPTABLE. WATER SHALL BE Poured OVER SUBBASE COURSE MATERIALS DURING COMPACTION.
- THE CONTRACTOR SHALL PERFORM ALL ROLLING AND SHAPING FROM THE LOW SIDE TO THE HIGH SIDE UNTIL EACH LAYER CONFORMS TO GRADES AS INDICATED AND LAYERS ARE SMOOTH.
- AFTER SUBBASE AGGREGATE INSTALLATION THE GEOTEXTILE FABRIC SHALL BE FOLDED BACK ALONG ALL BED EDGES. THE FABRIC SHALL REMAIN SECURE UNTIL ADJACENT SOILS ESTABLISH VEGETATION. ANY NECESSARY MEASURES SHALL BE TAKEN TO PREVENT SEDIMENT FROM WASHING INTO BEDS.
- THE ASPHALT AND CONCRETE MIXING PLANT, HAULING AND PLACING EQUIPMENT, AND INSTALLATION SHALL BE IN CONFORMANCE WITH NAPA IS 131 AND THE NJDOT STANDARD SPECIFICATIONS FOR ROAD AND BRIDGE CONSTRUCTION, 2019 OR LATEST VERSION.
- THE CONSTRUCTION SHALL BE PERFORMED IN CONFORMANCE WITH THE NJDOT STANDARD SPECIFICATIONS FOR ROAD AND BRIDGE CONSTRUCTION, 2019 OR LATEST VERSION.
- FINISHED PAVEMENTS SHALL SHOW NO MARKS FROM ROLLERS AND BE FREE FROM LOW LYING SPOTS SUBJECT TO PUDDLE FORMATION. ENTIRE SURFACE SHALL DRAIN PROPERLY. ALL ELEVATIONS MUST BE WITHIN 0.1 FT.

POROUS ASPHALT MIX DESIGN CRITERIA:

SIEVE SIZE (INCH/MM)	PERCENT PASSING (%)
0.75/19	100
0.50/12.5	85-100
0.375/9.5	55-75
No.4/4.75	10-25
No.8/2.36	5-10
No.200/0.075 (#200)	2-4

- BINDER CONTENT (AASHTO T164) 6-6.5%
- BINDER PERFORMANCE GRADE 64-22
- FIBER CONTENT BY TOTAL MIXTURE MASS 0.3% CELLULOSE OR 0.4% MINERAL RUBBER SOLIDS (SBR) CONTENT BY WEIGHT OF THE BITUMEN 1.5-3% or TBD
- AIR VOID CONTENT (ASTM D6752/AASHTO T275) 16.0-22.0%
- DRAINDOWN (ASTM D6390)* < 0.0%
- RETAINED TENSILE STRENGTH (AASHTO 283)** > 80%
- CANTABRO ABRASION TEST ENGAED SAMPLES (ASTM D7064-04) < 20%
- CANTABRO ABRASION TEST ON 7 DAY AGED SAMPLES < 30%

*CELLULOSE OR MINERAL FIBERS MAY BE USED TO REDUCE DRAINDOWN.

**IF THE TSR (RETAINED TENSILE STRENGTH) VALUES FALL BELOW 80% WHEN TESTED PER NAPA IS 131 (WITH A SINGLE FREEZE THAW CYCLE RATHER THAN 5), THEN IN STEP 4, THE CONTRACTOR SHALL EMPLOY AN ANTISTRIP ADDITIVE, SUCH AS HYDRATED LIME (ASTM C977) OR A FATTY AMINE, TO RAISE THE TSR VALUE ABOVE 80%.

CHRISTOPHER C. OBROPTA, Ph.D., P.E.
PROFESSIONAL ENGINEER - NJ LICENSE # 37632

PLAN REVISIONS
No. DATE DESCRIPTION

DRAFT

FLANDERS DRIVE DEVELOPMENT
GREEN INFRASTRUCTURE IMPLEMENTATION PROJECT
FRANDERS DRIVE, HILLSBOROUGH TOWNSHIP
SOMERSET COUNTY, NJ

RUTGERS
New Jersey Agricultural
Experiment Station

SHEET NAME
DT-5

14 COLLEGE FARM ROAD, NEW BRUNSWICK, NJ
PERMEABLE PAVEMENT DETAILS
DATE: XX/XX/XX
APPROVED: GCO
CHECKED: JAL
DRAWN: JAV